

GENERAL INFORMATION

ACCOUNTS: We encourage our customers to open a Rentals Unlimited charge. Call our Credit Department between 7:30 a.m. and 5:00 p.m. at 1-800-638-2926, or fill out the credit application in the back of the catalog.

CHARGE CARDS: We accept Visa, Master Card, American Express, and Discover.

DELIVERY: Our delivery fleet is always at your service. Call us to arrange delivery or pick-up at a reasonable cost. Any item delivered carries a one day minimum charge. Please call 1-800-638-2926.

FLAT TIRES: Tires are foam filled where appropriate to avoid flats, other flat tires are the customers responsibility. Tire truck service is available at a reasonable cost.

FUEL: Equipment leaves our yard full of fuel. For tanks larger than 1 gallon, the customer will be charged to fill the tank upon return.

HOURS: 7:00 A.M. - 5:30 P.M. Monday thru Friday, 7:30 A.M. - 5:30 P.M. Saturday
Closed Sunday.

SERVICE: We believe our rental equipment to be the best-serviced equipment available. We maintain a fleet of service vehicles to keep down time to a minimum.

CUSTOMER SERVICE/ DELIVERY: Call 1-800-638-2926 or (301) 972-6200

TIME PERIODS: 4 HRS = 4 consecutive hours or 4 p.m. thru 9 a.m. (Mon - thru Friday)
Day = 24 hours out or Saturday 4 p.m. thru Monday 9 a.m. (Max 8 hours use)
Week = 7 consecutive days, maximum 40 hours use
Month = 4 weeks, maximum 160 hours use
Saturday = a.m. rentals must be returned Saturday by 5:30 p.m. for a one day charge.
We charge for Sundays !

SAVE ON FUEL COSTS !

- DIESEL ● GASOLINE ● TANKS ●
 - PUMPS ● FLEET FUELING ●
 - FULL SERVICE ●
- Programs specifically designed to meet your needs.*

CALL TODAY FOR PRICE QUOTES AND INFORMATION



Since 1898

1-800-486-2477

LET RENTALS UNLIMITED BE YOUR PROPANE FILLING STATION

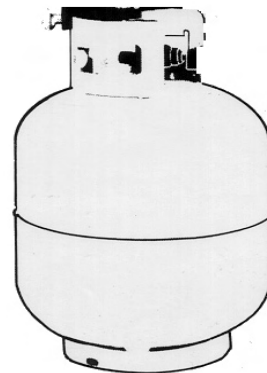

CONVENIENT ACCESS FOR

- MOTOR HOMES
- GAS GRILL TANKS
- HEATER TANKS



RU renting from us ? You should be!

Since 1956, Metropolitan Washington area homeowners, contractors and industry have relied on our first rate equipment, quality service, dependable delivery and competitive prices.

SATISFACTION guaranteed, or your day's rental is **FREE !**

Whether it's a home improvement project, residential, commercial or industrial project, give our experienced personnel a call or stop by any of our five locations. We strive to provide friendly and knowledgeable service you can depend on the first time and every time.

BECAUSE WE KNOW YOU HAVE OPTIONS,

We thank you for choosing Rentals Unlimited and for your continued support. We welcome your suggestions and recommendations on how to serve you better.



PLEASE USE OUR TOLL FREE NUMBER

(877) RU-RENTS
787-3687



Visit our web site at www.rentalsunlimited.com

OUR E-MAILADDRESS, customerservice@rentalsunlimited.com



FOR LOCAL CALLS TO OUR FIVE CONVENIENT BRANCHES.....

PARA SU CONVENIENCIA HABLAMOS ESPAÑOL

ROCKVILLE, MD

(301) 294-6066

FAX (301) 762-8527

CLARKSBURG, MD

(301) 972-6200

FAX (301) 916-9425

FREDERICK, MD

(301) 663-9200

FAX (301) 831-4559

STERLING, VA

METRO (703) 709-9300

(703) 437-7200

FAX (703) 709-9338

HAGERSTOWN, MD

(240) 420-0200

FAX (240) 420-0300



OUR FIVE LOCATIONS TO SERVE YOU

RENTALS UNLIMITED
HAGERSTOWN
 1458 S. Potomac St.
 (240) 420-0200



" HABLAMOS ESPAÑOL "

To Hagerstown

Hagerstown, Md

RENTALS UNLIMITED
FREDERICK
 36 Thomas Johnson Dr.
 (301) 663-9200

Frederick

To Baltimore

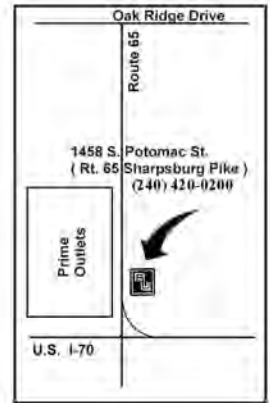

Rockville, Md

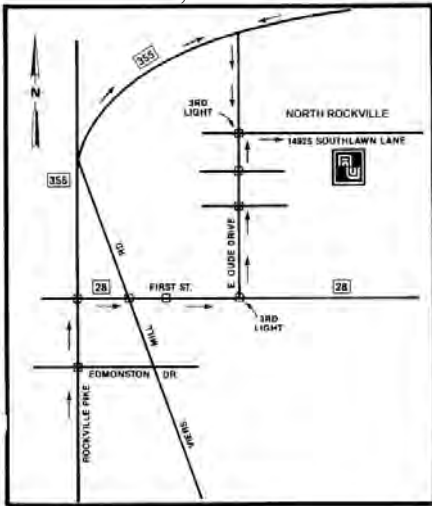

RENTALS UNLIMITED
CLARKSBURG
 24000 Frederick Rd.
 (301) 972-6200

Germantown

RENTALS UNLIMITED
ROCKVILLE
 14925 Southlawn Lane
 (301) 294-6066

Rockville

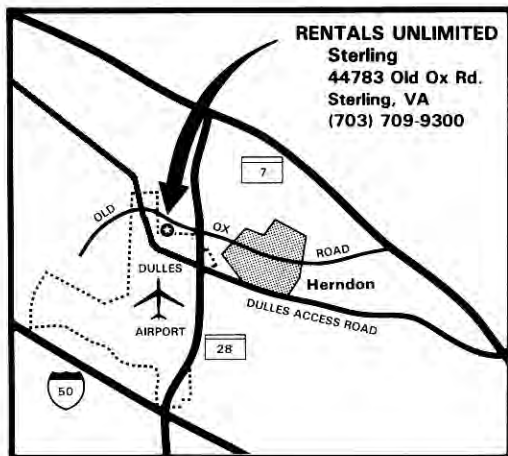

RENTALS UNLIMITED
Sterling
 44783 Old Ox Rd.
 Sterling, VA
 (703) 709-9300

RENTALS UNLIMITED
STERLING
 44783 Old Ox Road
 (703) 709-9300

INDEX

PAGE NO.	PAGE NO.	PAGE NO.
Aerator 64	Chain Saw, Electric 63	Floor Edger 60
Aerator, Core, Tow 64	Chain Saw, Gas 16"-32" 63	Floor Nailer 60
Air Compressor, Elec/Gas 55	Chain Saw, Hydraulic 36	Floor Polisher/Scrubber 61
Air Compressor, Gas/Diesel 29	Chipper, Large 67	Floor Sander 60
Air Hammer 30	Chop Saw 51	Floor Stapler 60
Air Purifier 44	Cold Plane 14	Floor Stripper 62
Air Scraper 30	Come-A-Long 56	Fork Attachment 12
Air Tamper 30	Commercial Weed Mower 66	Forklifts 21-23
Air Tank 57	Compaction Equipment 18-19	Forklift, Reach Type 23
Air Tools 55	Compaction Wheel 7	Forklift, Compact Reach 23
Airless Paint Sprayer 47	Compressor, Air-Gas/Diesel 29	Forklift, Rough Terrain 21
Aluminum Brake 72	Compressor, Sm. Gas/Elec 55	Forklift, Warehouse 22
Aluminum Bender 72	Concrete Bucket 41	Forklift, Yard Use 22
Aluminum Ramps 72	Concrete Chute 41	Fuel Tank 16
Appliance Hand Truck 70	Concrete Equipment 34-42	
Arrow Board 24	Concrete Grinder, Electric 38	Garage Jacks 56
Asphalt Curber 34	Concrete Grinder, Gas 38	Garden Tiller 65-66
Auger, Hydraulic 13,17	Concrete Mixer 34-35	Gator 3
Automotive Tools 56-59	Concrete Mixer Electric 34	Generator, 2.4kw-56kw 33
A/C Gauge Set 57	Concrete Plane, Gas 37	Georgia Buggy, Gas 42
A/C Vacuum Pump 57	Concrete Plane, Self-Prop 37	Georgia Buggy, Manual 42
	Concrete Polisher 38	Glass Suction Cups 70
Backhoe, 4 Wheel Drive 7	Concrete Vibrator 41	Grinder, Angle 41
Backhoe/Loader, Case 580 6,7	Conduit Bender 49	Grinder, Floor Gas/Electric 38
Backhoe/Loader, Terramite 7	Core Aerator 64	
Banding Tools 70	Core Drill, Diamond 40	Hammer, Air 20lb.-80lb 30
Bandsaw, Electric 51	Crack Chaser Please Call	Hammer, Electric 39
Barricade 36	CREDIT APPLICATION 73,75	Hammer, Rotary 40,53
Bed Edger 65	Curb Builder 34	Hammer, Small Demolition 40
Belt Sander 53	Cut Off Saw, Gas/Electric 35	Heat Gun 54
Bender, Conduit 49	Cutting/Brazing Outfit 32	Heaters 43
Bender, Pipe, Hydraulic 49		Heater, Electric 43
Blower, Back Pack 66	Dehumidifier 44	Heater, Kerosene 43
Blower, Ventilating 44	Dethatcher 64	Heater, Propane 43
Bobcat 10	Ditch Witch 15-16	Heavy Equipment Dollies 69,70
Boomlift, 40, - 60 25-26	Ditch Witch, Trencher w/Hoe 15	Hedge Trimmer, Gas/Electric 63
Boomlift, Articulated 45 25	Dolly, 4-Wheel 70	Highlift, Manual 69
Boomlift, Articulated 60,80 26	Door Jamb Saw 60	Hoe/Ram 6
Boomlift, Articulated 125 27	Dozer 5	Hose, Washdown, Hydrant 48
Boomlift, Articulated Electric 30 27	Dozer / Snow Blade 13	Hydraulic Auger 13,17
Boomlift, Electric 32 25	Drain Cleaning Equipment 49	Hydraulic Bottle Jack 56
Boomlift, Towable 25	Drills, Electric 1/2"-3/4" 52	Hydraulic Breaker 6,8,9,13,17
Breaker, Hydraulic 6,8,9,13,17	Drills, Right Angle 52	Hydraulic Broom 13
Brick Saw, Gas/Electric 34	Drywall Cart 71	Hydraulic House Jack 56
Broadcast Spreader, Tow 65	Drywall Lift 71	Hydroseeder 67
Broadcast Spreader 65	Drywall Screw Gun 52	
Broom Hydraulic 13	Duct Lift, Material Lift 69	Impact Wrench, Air 55
Broom Walk Behind 39	Dump Trailer 20	Impact Wrench, Electric 58
Brush Chipper, Large 67		Insulation Blower 47
Buffers 61	Edger, Bed 65	
Builders Level 38	Edger, Floor 60	Jackhammer 30,39
Bull Float 41	Edger, Trimmer 63,65	Jacks/Hoists 56,69
	Engine Crane 59	Jig Saw 51
Cable Plow 15	Engine Sling 59	Johnson Bars 70
Car Buffer 53	Engine Stand 56	Jumping Jack Tamper 19
Car Dolly 59	Excavators 8-9	
Carpet Cleaning Equipment 61		Knee Kicker 62
Carpet Dryer 61	Fans, 42", 48" 44	
Carpet Stapler 62	Fans, Pedestal 44	Ladder, Extension 71
Carpet Stretcher 62	Fans 44	Ladder, Step 71
Carpet/Tile Tools 62	Flail Mower 13	Landscaping Rake 65
Ceramic Tile Cutter 62	Finishing Sander 53	Laser Level 38
Ceramic Tile Saws 62	Flood Light 24	Lawn Edger 65
Chain Falls, 2-3 Ton 69		

INDEX

PAGE NO.	PAGE NO.	PAGE NO.
Lawn Mower, Self Prop 66	Ramp, Aluminum 72	Tile Cutter 62
Lawn Roller 65	Rebar Cutter Bender. 41	Tile Saw 62
Lawn/Garden Equipment 63-66	Road Signs 36	Tile Stripper 62
Leaf Blower 66	Rock Drill 30	Tiller 13,17,65,66
Leaf Vacuum 63	Rockhound 12	Torch, Cutting. 32
Level, Dumpy 38	Roll-A-Lift 69	Torque Wrench 57
Level, Laser 38	Rollers. 18-19	Tow Dolly 59
Light Tower 24	Roller, Impact. 18	Track Loaders 5,10
Line Striper. 47	Roofing Nailer 55	Traffic Cone 36
Linoleum Roller 62	Root Rake 10	Traffic Line Remover Please Call
Loader, Case 11,12	Rotary Hammer 40,53	Trailer, Dump 3, 20
Loader, Cat 953 5	Roto-Tiller. 65	Transit 38
Loader, Compact 17	Router 53	Transmission Jack 56
LogSplitter 63		Tree Spade 14
	Sandblasters 31	Trench Box 21
Magnetic Drill Press 54	Sander, Belt 53	Trench Roller 19
Magnetic Sweeper 41	Sander, Finishing. 53	Trencher, Ditch Witch 14,15,16
Material Handling Equip 69-70	Sander, Floor 60	Trencher, w/Backhoe 15
Measuring Wheel. 39	Sawzall. 51	Troweling Machine, 36"-48". . . . 42
Mechanic Tools 57-58	Saw, Circular 7 1/4"-16". . . . 51	Trowelling Machine, Ride On . . . 42
Metal Detector 72	Saw, Concrete Air 36	Truck, 12' Moving. 1
Mitre Box, Electric 12",15" . . . 51,52	Saw, Cut Off Gas/Electric 35	Truck, 12' Stake Body 2
Mixers 34,35	Saw, Door Jamb 60	Truck, 18' Moving. 1
Mixer, Concrete 34,35	Saw, Multi-Purpose 35	Truck, 18' Flat Bed 2
Mixer, Mortar 35	Scabber Please Call	Truck, Boom 35' 4
Moving Pads 70	Scaffolding 46	Truck, Delivery 2
Moving Trucks 1	Scissor Lift, 19'- 26' 27	Truck, Econoline Van. 1
Mole, 3"Air 30	Scissor Lift, 25'- 40' 28	Truck, Flat Bed Dump 3
	Scissor Lift, 29' Genie Lift 27	Truck, Pick Up 2
Nailer, Air-Finish 55	Screed, Wet 42	Turbo Dryer 61
Nailer, Air-Framing. 55	Screw Jack. 56	
Nailer, Air Roofing 55	Service Jack. 56	Utility Pump. 48
Nailer ,Floor 60	Seeder, Commercial 64	Utility Vehicle 4
Nibbler 54	Shear, Metal. 54	
	Slab Saw 36-37	Vacuums, Wet/Dry 61
Pad Tamper 19	Snake, Electric. 49	Vacuum, Billy Goat. 63
Paint Sprayer 47	Snake, Manual. 49	Vacuum, Shop. 61
Paint Striper 47	Sod Cutter 64	Vacuum, Upright 61
Pallet Truck 69	Soil Pipe Cutter 50	Van, Delivery 2
Pattern Pistol 47	SOLICITUD DE CREDITO. 75	Ventilating Blower 44
Paving Breaker, Electric. 39	Sprayer, Paint -Gas / Electric . . . 47	Vibrator, Electric. 41
Personnel Lift 25, 28	Spreader, Fertilizer -Towable. . . . 65	
Pick-Up Truck. 2	Spreader, Fertilizer. 65	Wallpaper Steamer 47
Piercing Tool. 30	Stapler, Air-Framing 55	Warehouse Type Hand Truck 70
Pipe Cutter. 50	Stapler, Air-Masonite 55	Water Tank, 200, 1000 gal. 68
Pipe Die 50	Stapler, Air-Roofing 55	Weedeater 63
Pipe Vise 50	Stapler, Carpet. 62	Weed/Grass Mower 66
Plane, Block. 54	Stapler, Masonite 55,60	Welder, Diesel Trailered. 32
Plane, Door 54	Stapler, Hardwood Floor 60	Welder, Gas 32
Plumbing Tools 49-50	Steam Cleaner. 45	Welder, Mig 32
Pole Saw 63	Storage Container 21	Welding Equipment 32
Porta Power 56	Straw Blower, Large. 68	Wet Dry Vacuum 61
Post Driver, Air 30	Straw Blower, Small. 68	Wet Screed 42
Post Driver, Hand. 68	Stud Gun 60	Wheelbarrow 42
Post Hole Digger 68	Stump Grinder 67	Wheel Loader 6
Power Rake 64		
Power Rake, Harley 14	Tamper, Air 30	
Power Rammer 19	Tamper, Jumping Jack 19	
Power Vise. 50	Tamper, Jumping Jack Elec 19	
Pressure Washers 45	Tamper, Pad. 19	
Pruner/ Pole Saw. 63	Terramite 7	
Pumps 48	Thatcher. 64	
Pump, Water - Gas / Electric . . . 48	Threading Machine 50	
	Tiger Saw. 51	



TRUCKS



12' TRUCK

CODE 9220 PLUS FUEL		
DAY	\$ 60.00	.36 MILE
WEEK	\$ 240.00	.36 MILE
MONTH	\$ 720.00	.36 MILE

WITH RAMPS & AUTOMATIC TRANSMISSION

MOVING PADS (PER DOZEN)

CODE 5715	
DAY	\$ 10.00
WEEK	\$ 32.00
MONTH	\$ 60.00

HAND TRUCK

CODE 5705	
DAY	\$ 10.00
WEEK	\$ 32.00
MONTH	\$ 60.00

See page 69 & 70 for other items to help you with your move !

WE CARRY MOVING BOXES !

18' TRUCKS WITH LIFT GATES

AUTOMATIC TRANSMISSION



18' TRUCK

CODE 9230 PLUS FUEL		
DAY	\$ 80.00	.44 MILE
WEEK	\$ 320.00	.44 MILE
MONTH	\$ 960.00	.44 MILE



We Sell Moving Boxes

ECONOLINES

**AUTOMATIC TRANSMISSION
8 1/2' OF LOAD SPACE**



CODE 9210 PLUS FUEL		
DAY	\$ 55.00	.33 MILE
WEEK	\$ 220.00	.33 MILE
MONTH	\$ 660.00	.33 MILE



TRUCKS

DELIVERY VAN

AUTOMATIC TRANSMISSION



CODE 9215 PLUS FUEL		
DAY	\$ 60.00	.36 MILE
WEEK	\$ 240.00	.36 MILE
MONTH	\$ 720.00	.36 MILE

PICK UP TRUCKS

AUTOMATIC TRANSMISSION

8' TRUCK BED



CODE 9250 PLUS FUEL		
DAY	\$ 55.00	.33 MILE
WEEK	\$ 220.00	.33 MILE
MONTH	\$ 660.00	.33 MILE

AUTOMATIC TRANSMISSION

12' STAKE TRUCKS

3 TO 4 FT. SIDES

2 TON CAPACITY



CODE 9260 PLUS FUEL		
DAY	\$ 75.00	.44 MILE
WEEK	\$ 300.00	.44 MILE
MONTH	\$ 900.00	.44 MILE

TRUCKS



18' TRUCK FLAT BED TRUCKS

5 TON CAPACITY



LIFT GATES

CODE 9271 PLUS FUEL		
DAY	\$ 95.00	.49 MILE
WEEK	\$ 380.00	.49 MILE
MONTH	\$ 1140.00	.49 MILE

12' FLAT BED DUMP TRUCKS



5 TON CAPACITY

CODE 9290 PLUS FUEL		
DAY	\$ 120.00	.55 MILE
WEEK	\$ 480.00	.55 MILE
MONTH	\$ 1440.00	.55 MILE



TRUCKS

35' BOOM TRUCK



350 LB CAPACITY



CODE 9240 PLUS FUEL		
4 HRS	\$ 250.00	.40 MILE
DAY	\$ 400.00	.40 MILE
WEEK	\$ 1200.00	.40 MILE
MONTH	\$ 4000.00	.40 MILE

UTILITY VEHICLE

900 LB TOTAL LOAD CAPACITY



CODE 5152	
DAY	\$ 50.00
WEEK	\$ 175.00
MONTH	\$ 500.00

**IDEAL FOR GETTING AROUND THE JOB SITE,
OR USE AT HOME FOR TRANSPORTING HEAVY
LOADS IN YOUR YARD**

EARTH MOVING EQUIPMENT



CASE 850K

BLADE WIDTH 8'8"

WEIGHT 22,000 LBS
OVERALL LENGTH 14.5'
OVERALL HEIGHT 9'

WILL DIG 1' 7" BELOW GRADE

CODE 8766

DAY	\$ 450.00
WEEK	\$ 1800.00
MONTH	\$ 7200.00



CASE 650K

WEIGHT 18,000 LBS

CODE 8765

DAY	\$ 350.00
WEEK	\$ 1400.00
MONTH	\$ 5600.00

ENCLOSED CAB
WITH HEAT AND A/C

953 CAT TRACK LOADER

- 133 HP ENGINE
- 33,389 LB OPERATING WT.
- 2.4 YD³ GENERAL PURPOSE BUCKET

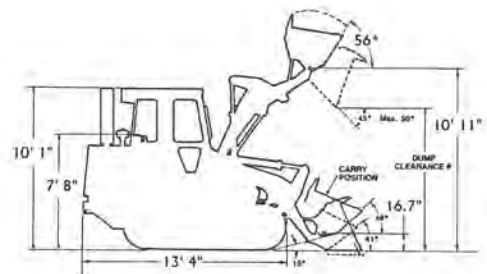

CODE 8797

DAY	\$ 595.00
WEEK	\$ 2100.00
MONTH	\$ 8400.00



EARTH MOVING EQUIPMENT

WHEEL LOADER

110 HORSEPOWER
20,585 LB OPERATING WEIGHT
2.25³ YD GENERAL PURPOSE BUCKET

**SERVED
WEEKLY**



CODE 8770	
DAY	\$ 400.00
WEEK	\$ 1400.00
MONTH	\$ 4000.00

580 BACKHOE LOADERS 4 WHEEL DRIVE

•75 HP • 8'11" TRANSPORT HEIGHT • 14'2" MAX DIGGING DEPTH
•FRONT BUCKET CAPACITY 5200 LBS TO FULL LIFT HEIGHT
•FRONT BUCKET LIFT OVER HEIGHT 11'2"
•.87 CUBIC YARD STRUCK • 1.03 CU HEAPED •82" BUCKET WIDTH •OPERATING WEIGHT 12,820 LBS. •

12" 18" 24" BUCKETS AVAILABLE



**WITH
HYDRAULIC
BREAKER**

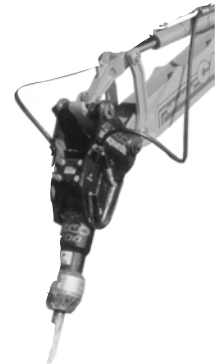

CODE 8730	
DAY	\$ 200.00
WEEK	\$ 700.00
MONTH	\$ 2000.00

**STANDARD BACKHOE
DIGGING DEPTH 14'2"**

CODE 8785	
DAY	\$ 495.00
WEEK	\$ 1732.50
MONTH	\$ 4950.00

EARTH MOVING EQUIPMENT



CASE 580 SUPER MII BACKHOE WITH 4 WHEEL DRIVE

**EXTENDAHOE
DIGGING DEPTH 18' 3"**

**ENCLOSED CAB WITH
HEAT AND A/C**

12" 18" 24" BUCKETS AVAILABLE



CODE 8780	
DAY	\$ 240.00
WEEK	\$ 840.00
MONTH	\$ 2400.00

WE HAVE TRENCH BOXES ! (See Page 21)

**SHEEPSFOOT COMPACTION WHEEL
TO BE USED WITH CASE BACKHOE ONLY**

CODE 8776	
DAY	\$ 100.00
WEEK	\$ 320.00
MONTH	\$ 600.00

**PUTS IN LIFTS OF ABOUT 18 TO 24"
ON A 40 TO 45 DEGREE ANGLE. DEPENDS ON
SOIL CONDITIONS. 6-10 PASSES REQUIRED
FOR ADEQUATE SOIL COMPACTION.**

COMPACT LOADER-BACKHOE TERRAMITE MODEL T-5

**WIDTH : 4' 1"
HEIGHT : 6' 10"
DIGGING DEPTH : 8' 4"
DUMP HEIGHT : 6' 7"
20 HP ENGINE
WEIGHT : 2650 Lbs**



16" BUCKET

CODE 8735	
DAY	\$ 165.00
WEEK	\$ 577.50
MONTH	\$ 1650.00



EARTH MOVING EQUIPMENT

SUB-COMPACT EXCAVATOR

ONLY 28" WIDE !



**13"
BUCKET**

SPECIFICATIONS

Overall width.....28"
 Bucket width.....13"
 Max. digging depth.....4' 10"
 (WITH BLADE DOWN TO THE REAR)
 Max. dumping height.....6' 7"
 Max. reach.....8' 11"
 Machine weight.....2300 lbs

CODE 8714	
DAY	\$ 200.00
WEEK	\$ 700.00
MONTH	\$ 2000.00

SPECIFICATIONS

MINI EXCAVATOR

Overall length.....12'
 Overall width.....3' 3"
 Overall height.....7' 11"
 Bucket width.....16"
 Max. digging depth.....7' 1"
 (WITH BLADE DOWN TO THE REAR)
 Max. digging height.....11' 10"
 Max. reach.....12' 11"
 Machine weight.....4090 lbs



**16"
BUCKET**

Excavator with Hydraulic
Breaker



CODE 8703	
DAY	\$ 290.00
WEEK	\$ 1015.00
MONTH	\$ 2900.00

CODE 8704	
DAY	\$ 165.00
WEEK	\$ 577.50
MONTH	\$ 1650.00

EARTH MOVING EQUIPMENT



**10' 5" DIGGING DEPTH
17' 7" REACH**

MID SIZED EXCAVATOR



WIDTH 5'9"

OPERATING WT 8245 LBS



CODE 8705	
DAY	\$ 195.00
WEEK	\$ 682.50
MONTH	\$ 1950.00

WE HAVE TRENCH BOXES ! (See Page 21)

**12", 18" AND 24"
BUCKETS AVAILABLE**

LARGE EXCAVATOR

- FULLY ELECTRONIC CONTROLS
- AUTO TRAVEL SPEED SELECTOR
- 3 POWER CONTROL WORK

MODES

- ALL WEATHER CAB
- MAX DIGGING DEPTH 20 FEET
 - 20,000 LIFT CAPACITY
 - 28' REACH

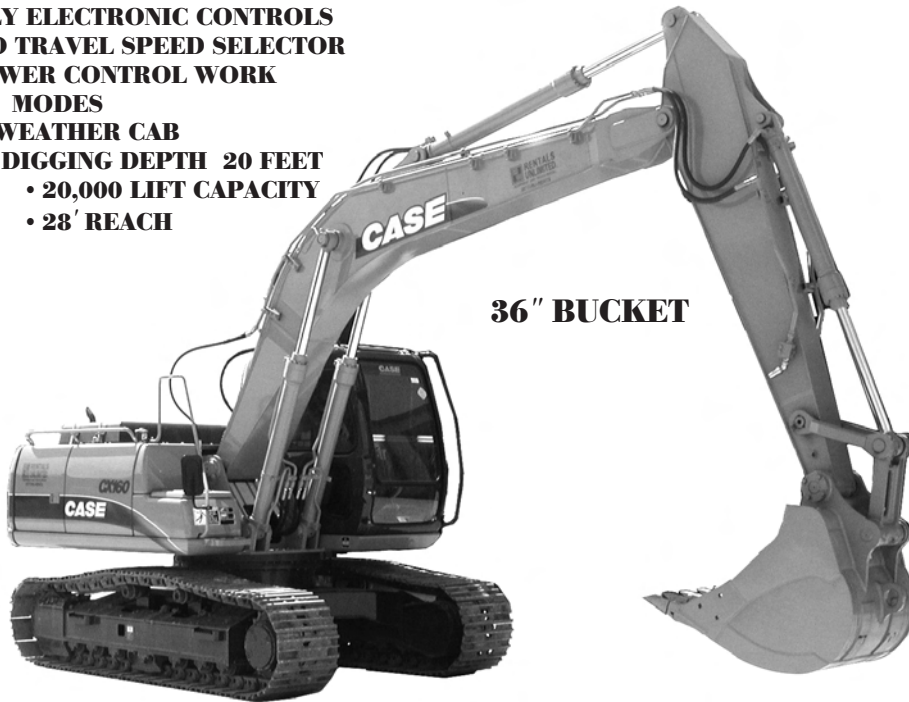

36" BUCKET

THUMB ATTACHMENT



CODE 8701	
DAY	\$ 125.00
WEEK	\$ 437.50
MONTH	\$ 1250.00

EXCAVATOR

CODE 8709	
DAY	\$ 450.00
WEEK	\$ 1575.00
MONTH	\$ 4500.00

EXCAVATOR W/BREAKER ATTACHMENT

CODE 8786	
DAY	\$ 1000.00
WEEK	\$ 3500.00
MONTH	\$10000.00





EARTH MOVING EQUIPMENT

RUBBER TRACK LOADER



Rubber Track System for working in soft, muddy ground conditions where wheel loaders would bog down.

WEIGHT 7244 LBS
WIDTH 68" HEIGHT 76.3"
CAPACITY 1900 LBS

CODE 8725		Tooth Bucket
DAY	\$ 295.00	\$ 15.00
WEEK	\$ 1032.50	\$ 52.50
MONTH	\$ 2950.00	\$ 150.00

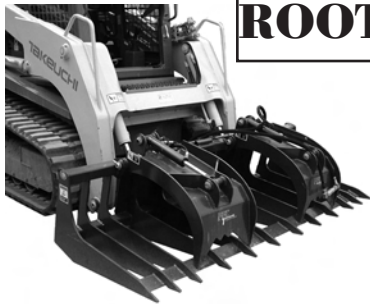

ROOT RAKE W/GRAPPLE ATTACHMENT

91" WIDE

FOR USE WITH CODE 8728 ONLY

CODE 8727	
DAY	\$ 100.00
WEEK	\$ 350.00
MONTH	\$ 1000.00

LARGE RUBBER TRACK LOADER



CAB W/HEAT AND A/C



WEIGHT 10,700 LBS
WIDTH 81" HEIGHT 92"
LIFT 126"
CAPACITY 2470 LBS

CODE 8728	
DAY	\$ 395.00
WEEK	\$ 1382.50
MONTH	\$ 3950.00

EARTH MOVING EQUIPMENT



CASE SKID LOADER



LIFT CAPACITY 1500 LBS
SMOOTH BUCKET
 (TOOTH BUCKET IS AVAILABLE)
54 H.P.
62" WIDE

TOTAL WT. 5460 LBS.

	CODE 8715	Tooth Bucket
DAY	\$ 175.00	\$ 15.00
WEEK	\$ 612.50	\$ 52.50
MONTH	\$ 1050.00	\$ 150.00

MEDIUM CASE SKID LOADER



13.9 CU. FT. BUCKET CAP.
LIFT CAPACITY 1700 LBS.
 • 73" WIDE
 • 60 HP. DIESEL ENGINE
OPTIONAL TOOTH BUCKET

TOTAL WT. 6085 LBS

	CODE 8720	Tooth Bucket
DAY	\$ 190.00	\$ 15.00
WEEK	\$ 665.00	\$ 52.50
MONTH	\$ 1140.00	\$ 150.00



ATTACHMENTS

LARGE SKIDSTEER



TOTAL WEIGHT 8805 LBS
LIFT CAPACITY 2400 LBS

	CODE 8740	Tooth Bucket
DAY	\$ 210.00	\$ 15.00
WEEK	\$ 735.00	\$ 52.50
MONTH	\$ 1260.00	\$ 150.00

**SERVICED
WEEKLY**



FORKLIFT ATTACHMENT

1050 LBS CAPACITY 2400 LBS

CODE 8712	
DAY	\$ 50.00
WEEK	\$ 160.00
MONTH	\$ 300.00

CODE 8713	
DAY	\$ 50.00
WEEK	\$ 160.00
MONTH	\$ 300.00

ROCKHOUND ATTACHMENT (For Code 8720, 8740, 8725)

CODE 8711	
DAY	\$ 150.00
WEEK	\$ 525.00
MONTH	\$ 1500.00



76" Width

ATTACHMENTS



HYDRAULIC TILLER



6' WORKING WIDTH

(For Code 8720, 8740, 8725)

CODE 8710	
DAY	\$ 150.00
WEEK	\$ 525.00
MONTH	\$ 1500.00

FLAIL MOWER



72" CUTTING WIDTH

CODE 8708	
DAY	\$ 200.00
WEEK	\$ 700.00
MONTH	\$ 2000.00

NOT FOR 40XT

HYDRAULIC BROOM



CODE 8717	
DAY	\$ 60.00
WEEK	\$ 210.00
MONTH	\$ 600.00

DOZER / SNOW BLADE

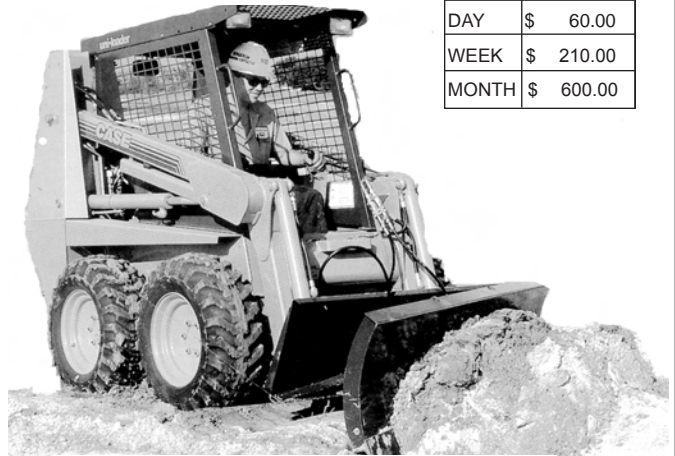

HYDRAULIC ANGLE BLADE

CODE 8718	
DAY	\$ 60.00
WEEK	\$ 210.00
MONTH	\$ 600.00

HYDRAULIC AUGER

BIT SIZES

9" - 24"

EXTENSIONS AVAILABLE



30" ALSO AVAILABLE EXTRA CHARGE

CODE 8723	
DAY	\$ 60.00
WEEK	\$ 210.00
MONTH	\$ 600.00

HYDRAULIC BREAKER

(For Code 8720 or 8740)



CODE 8722	
DAY	\$ 150.00
WEEK	\$ 525.00
MONTH	\$ 1500.00



ATTACHMENTS

COLD PLANE "TEETH EXTRA"



CODE 8719	
DAY	\$ 175.00
WEEK	\$ 612.50
MONTH	\$ 1750.00

MILLS CONCRETE
OR ASPHALT
HYDRAULIC SIDE SHIFT
12" CUT

HARLEY POWER RAKE



CODE 8747	
DAY	\$ 150.00
WEEK	\$ 525.00
MONTH	\$ 1500.00

83" WIDTH

TRENCHER ATTACHMENT

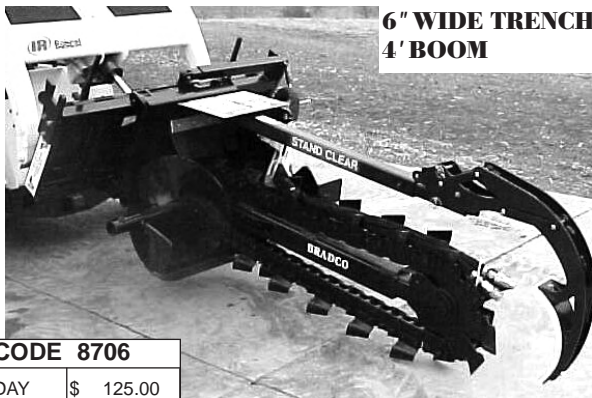

CODE 8706	
DAY	\$ 125.00
WEEK	\$ 437.50
MONTH	\$ 1250.00

For Code 8720 Only

HYDRAULIC BUCKET BROOM (FOR 60, 85XT)



CODE 8702	
DAY	\$ 100.00
WEEK	\$ 350.00
MONTH	\$ 1000.00

TREE SPADE



TRIMMED BALL SPECS:
WEIGHT 380 lbs
DIAMETER 30"

PRICE IS FOR LOADER AND SPADE

340 LBS
HEIGHT 66"
WIDTH 95"
LENGTH 82"

CODE 5124	
DAY	\$ 395.00
WEEK	\$ 1382.50
MONTH	\$ 3110.00

TRENCH DIGGERS



DITCH WITCH 3700 W/ BACKHOE



CODE 9131	
DAY	\$ 325.00
WEEK	\$ 1137.50
MONTH	\$ 3250.00

TRAILER AVAILABLE

SPECIFICATIONS:

TRENCHER- 6" WIDE X 45" DEPTH
 BACKHOE- 13" WIDE X 6'6" DEPTH
 WEIGHT- 7300 LBS

OFF SET CAPABILITY

TRENCHER ONLY WITHOUT BACKHOE

CODE 9130	
DAY	\$ 295.00
WEEK	\$ 1032.50
MONTH	\$ 2950.00

CABLE PLOW 44.5" MACHINE WIDTH



FOR CABLE OR PIPE

CODE 9145	
DAY	\$ 200.00
WEEK	\$ 700.00
MONTH	\$ 2000.00



TRENCH DIGGERS



300 GAL DIESEL FUEL TANK



CODE 8809	
DAY	\$ 50.00
WEEK	\$ 50.00
MONTH	\$ 50.00

1230 DITCH WITCH 4" X 24" TRENCHER



FITS THROUGH STANDARD GATE

**LENGTH : 73"
WIDTH : 33"
13 HP
900 LBS**

CODE 9110	
4 HRS	\$ 75.00
DAY	\$ 125.00
WEEK	\$ 437.50
MONTH	\$ 1250.00

TRAILERS AVAILABLE

1820 DITCH WITCH 4" X 36" TRENCHER



**LENGTH : 78"
WIDTH : 45"
18 HP
1300 LBS**

CODE 9120	
4 HRS	\$ 100.00
DAY	\$ 150.00
WEEK	\$ 525.00
MONTH	\$ 1500.00

COMPACT LOADER



COMPACT UTILITY TRACK LOADER



25 HP ENGINE
WEIGHT 2270 LBS
44" WIDE
43" HEIGHT
DUMP HEIGHT 46"

VERSATILE AND EASY TO OPERATE !

CODE 8630		TOOTH BUCKET
DAY	\$ 150.00	\$ 15.00
WEEK	\$ 525.00	\$ 52.50
MONTH	\$ 1500.00	\$ 150.00



HYDRAULIC AUGER

AUGER SIZES
9", 12", 18" AND 24"

CODE 8635	
DAY	\$ 50.00
WEEK	\$ 175.00
MONTH	\$ 500.00



TILLER

40" WIDTH
6" DEPTH
REVERSIBLE TINE
ROTATION

CODE 8640	
DAY	\$ 75.00
WEEK	\$ 262.50
MONTH	\$ 750.00



HYDRAULIC BREAKER

175 FT.-LBS OF FORCE
1200 BLOWS/MIN.
VERTICAL OR
HORIZONTAL BREAKING

CODE 8645	
DAY	\$ 125.00
WEEK	\$ 437.50
MONTH	\$ 1250.00



CONCRETE BUCKET

200 lb CAPACITY

CODE 8650	
DAY	\$ 30.00
WEEK	\$ 96.00
MONTH	\$ 180.00



ROLLERS

SMOOTH DRUM ROLLER

SPECIFICATIONS

OPERATING WEIGHT 11,100 LBS
 ROLLING WIDTH 56"
 CENTRIFUGAL FORCE 10 TON

CODE 1720	
DAY	\$ 250.00
WEEK	\$ 875.00
MONTH	\$ 2500.00



PAD FOOT VIBRATORY SOIL COMPACTOR

OPERATING WEIGHT: 11,100 LBS.
 DRUM WIDTH: 54"
 CENTRIFUGAL FORCE: 16,000 LBS.

CODE 1746	
DAY	\$ 275.00
WEEK	\$ 962.00
MONTH	\$ 2750.00



25 TON SMOOTH DRUM ROLLER

SPECIFICATIONS

OPERATING WEIGHT 22,928 LBS
 ROLLING WIDTH 34"
 CENTRIFUGAL FORCE 53,100 LBS.



CODE 1748	
DAY	\$ 400.00
WEEK	\$ 1400.00
MONTH	\$ 4000.00

VIBRATORY ROLLERS



1.5 TON

OPERATING WEIGHT .. 2430 LBS
 DRUM WIDTH 35.4"
 FRONT DRUM FORCE .. 3000 LBS
 REAR DRUM STATIC
 LIFT CAPACITY:
 ASPHALT 4" SOIL 10"

TRAILER AVAILABLE

CODE 1735	
DAY	\$ 125.00
WEEK	\$ 437.50
MONTH	\$ 1250.00



LENGTH 100"
 DRUM WIDTH 47.2"
 HEIGHT 67.5"
 OPERATING WEIGHT 6,100 LBS.
 COMPACTION 4-6 TON

CODE 1710	
DAY	\$ 200.00
WEEK	\$ 700.00
MONTH	\$ 2000.00

COMPACTION EQUIPMENT



TRENCH ROLLER W/ REMOTE CONTROL

IMPACT FORCE UP TO 14,000 LBS
DRUM WIDTH: 32"
OPERATING WEIGHT : 3020 LBS



CODE 1726	
DAY	\$ 200.00
WEEK	\$ 700.00
MONTH	\$ 2000.00

**ALL OF OUR SALES ITEMS
 CAN BE DELIVERED
 TO YOUR JOBSITE**



GAS POWER RAMMER



**IMPACT FORCE:
 2475LBS/BLOW**
**WEIGHT :
 132 LBS**
**SHOE SIZE:
 11.2" X 12.9"**

CODE 1750	
4 HRS	\$ 40.00
DAY	\$ 55.00
WEEK	\$ 192.50
MONTH	\$ 550.00

ELECTRIC POWER RAMMER



**115V AC
 15 AMP**

CODE 1755	
4 HRS	\$ 40.00
DAY	\$ 55.00
WEEK	\$ 176.00
MONTH	\$ 330.00

5 HP PAD TAMPER

CENTRIFUGAL FORCE 3350 LBS.
PLATE SIZE 19.6" W X 22" L
WEIGHT 196 LBS.



CODE 1715	
4 HRS	\$ 35.00
DAY	\$ 50.00
WEEK	\$ 175.00
MONTH	\$ 500.00



DUMP TRAILER

3 TON CAPACITY

6 X 10 FOOT BED

ELECTRIC DUMP

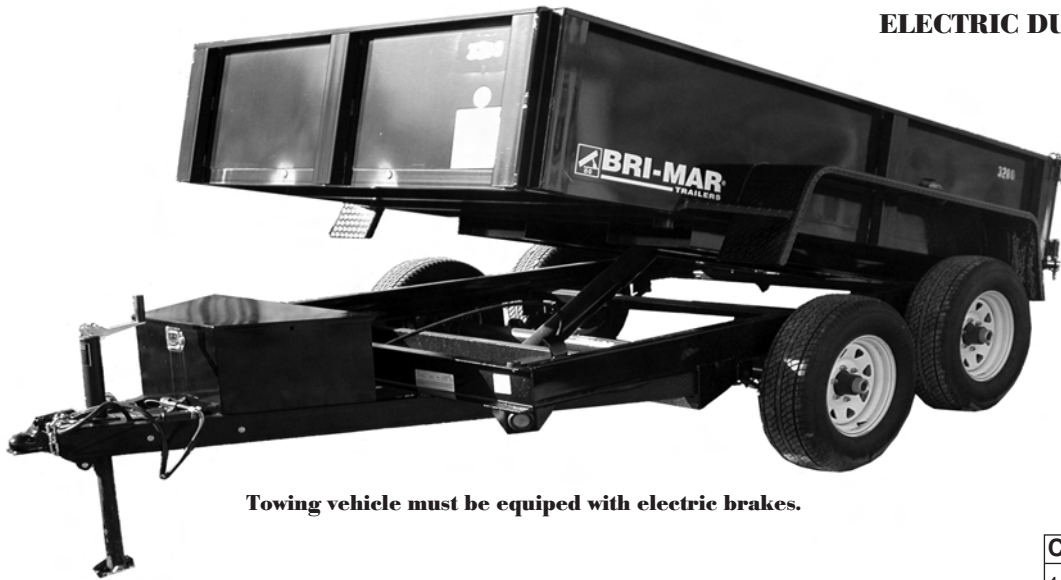

Towing vehicle must be equipped with electric brakes.

CODE	8934
4 HRS	\$ 50.00
DAY	\$ 75.00
WEEK	\$ 300.00
MONTH	\$ 750.00

OTHER TRAILERS AVAILABLE

TR Cellular Accessories, Inc.

Office: (301) 831-4967
 Toll Free: 1-877-909-8722
 Fax: (301) 831-4968
www.nextelplus.com



“Specializing in **NEXTEL** Accessories”



- CHARGERS
- CASES
- HANDSFREE
- FACEPLATES

- BATTERIES
- AUDIO
- SOFTWARE
- CABLES



“Nothing But TR ... ific Accessories”



FORKLIFTS

STORAGE CONTAINERS

8' X 20'



**KEEP YOUR JOB SITE
TOOLS AND EQUIPMENT SAFE**

CODE 8962	
DAY	\$ 150.00
WEEK	\$ 150.00
MONTH	\$ 150.00

TRENCH BOXES



**4 Feet High
8 Feet Long**

36 or 48 Inch Width

CODE 7712	
DAY	\$ 100.00
WEEK	\$ 350.00
MONTH	\$ 1000.00

ROUGH TERRAIN FORKLIFT



**LIFT HEIGHT
21 FEET**

6,000 lb CAPACITY

CODE 5630	
DAY	\$ 175.00
WEEK	\$ 612.50
MONTH	\$ 1750.00



FORKLIFTS

SOLID TIRES FOR WAREHOUSE USE

**DIFFERENT MODELS WITH
PROPANE AND GAS FUELS**



5,000 LB

CODE 5605	
DAY	\$ 100.00
WEEK	\$ 350.00
MONTH	\$ 1000.00

EXTENSION FORKS

CODE 5690	
DAY	\$ 25.00
WEEK	\$ 75.00
MONTH	\$ 150.00

CARPET POLE

CODE 5695	
DAY	\$ 25.00
WEEK	\$ 75.00
MONTH	\$ 150.00

3,000 LB

CODE 5606	
DAY	\$ 100.00
WEEK	\$ 350.00
MONTH	\$ 1000.00

PNEUMATIC TIRES



5,000 LB

CODE 5607	
DAY	\$ 110.00
WEEK	\$ 385.00
MONTH	\$ 1100.00

SIDE SHIFT AVAILABLE

8,000 LB.

CODE 5609	
DAY	\$ 150.00
WEEK	\$ 525.00
MONTH	\$ 1500.00

CODE 5613	
DAY	\$ 5.00
WEEK	\$ 15.00
MONTH	\$ 30.00

12,000 LB.

CODE 5612	
DAY	\$ 200.00
WEEK	\$ 700.00
MONTH	\$ 2000.00



**DIFFERENT MODELS WITH
PROPANE AND GAS FUELS**

FORKLIFTS



COMPACT REACH FORKLIFT



**5,500 LB CAPACITY
18' LIFT HEIGHT**

WIDTH 71.5"

HEIGHT 75.6"

LENGTH 144.2"



CODE 5638

DAY	\$ 225.00
WEEK	\$ 787.50
MONTH	\$ 2250.00

**SERVICED
WEEKLY**



REACH FORKLIFT

**6,000 LB CAPACITY
42' REACH**



MODEL	ZB6042
MAX LIFT CAPACITY	6000 LBS
MAX LIFT HEIGHT	42 FT
OVERALL WEIGHT	22000 LBS
OVERALL HEIGHT	7.9 FT
LENGTH LESS FORKS	19.41 FT
GROUND CLEARANCE	19 IN
OUTSIDE TURN RADIUS	11.75 FT

CODE 5648

DAY	\$ 275.00
WEEK	\$ 962.50
MONTH	\$ 2750.00



LIGHTS

LIGHT TOWER

Compact and light weight with two lights that telescope to 21 feet, this unit is available with or without portable generator. You can plug the unit into existing power or use a 3KW or larger generator to power the lights.

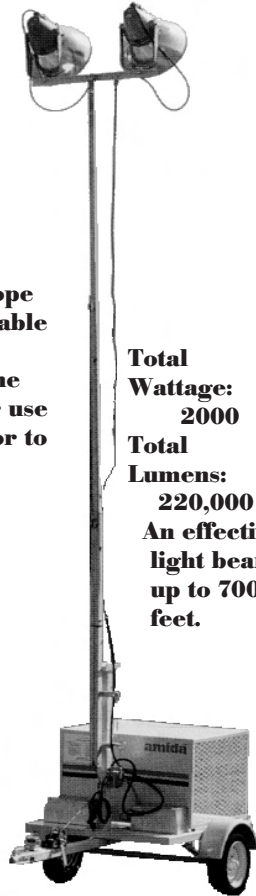

Total Wattage: 2000
Total Lumens: 220,000
An effective light beam up to 700 feet.

CODE 0760		
DAY	\$ 50.00	W/O GEN
WEEK	\$ 160.00	W/O GEN
MONTH	\$ 300.00	W/O GEN

CONTRACTORS LIGHT TOWER

Diesel Powered
4 -1000 WATT LIGHTS
30' TOWER HEIGHT
5.6 KW GENERATOR

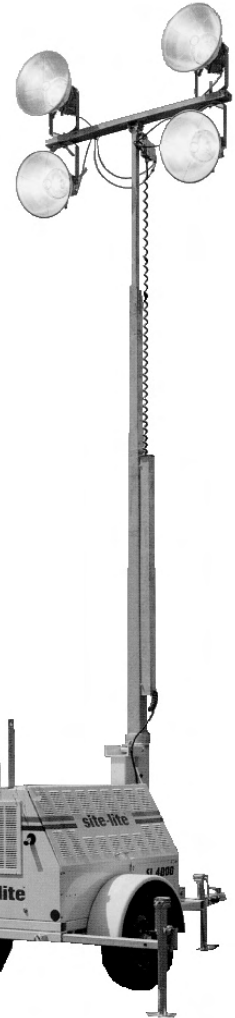

PRICES BASED
ON AN 8 HR
USE WITHIN A
24HR PERIOD

CODE 0770	
DAY	\$ 125.00
WEEK	\$ 437.50
MONTH	\$ 1250.00

FLASHING ARROW BOARD



CODE 0750	
DAY	\$ 55.00
WEEK	\$ 192.50
MONTH	\$ 550.00

FLOOD LIGHTS



500 watt Quartz lamp
Adjustable base
For indoor or outdoor use

CODE 5418	
DAY	\$ 6.00
WEEK	\$ 19.20
MONTH	\$ 36.00



Twin 500 watt quartz lamps
Extends to 6' height
For indoor or outdoor use

CODE 5420	
DAY	\$ 15.00
WEEK	\$ 48.00
MONTH	\$ 90.00

BOOM LIFTS



**TOWABLE BY TRUCK,
CAR OR VAN**



PERSONNEL LIFT \ UNIVERSAL CRANE

SPECIFICATIONS:
PLATFORM HEIGHT..... 35'
**SIDE REACH FROM CENTER OF
 ROTATION20'**
UNIT WEIGHT 3400 LBS.
CAPACITY..... 500 LBS.
**TRAVEL HEIGHT WITH BOOM
 STOWED 78"**



**PERMANENT HITCH WITH
2" BALL REQUIRED**

CODE 8832	
4 HRS	\$ 110.00
DAY	\$ 165.00
WEEK	\$ 577.50
MONTH	\$ 1650.00

45' ARTICULATED BOOM

GAS OR LPG POWERED

2 WHEEL DRIVE

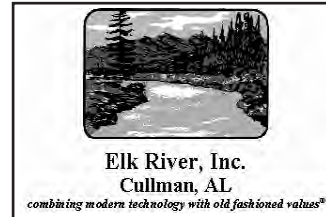

WE HAVE ELK RIVER
FALL PROTECTION
EQUIPMENT
AVAILABLE FOR SALE



VERTICAL REACH..... 45'
HORIZONTAL REACH... 24'6"
STOWED LENGTH..... 21'5"
OVERALL WIDTH..... 6'10"
STOWED HEIGHT..... 7'5"
WEIGHT.....15,100 LBS

4 WHEEL DRIVE

CODE 8846	
DAY	\$ 275.00
WEEK	\$ 825.00
MONTH	\$ 2475.00



BOOM LIFTS

SELF PROPELLED BOOM LIFTS

60' LIFT HEIGHT

CODE 8860	
DAY	\$ 400.00
WEEK	\$ 1200.00
MONTH	\$ 3600.00

GAS OR LPG POWERED

4 WHEEL DRIVE

CODE 8864	
DAY	\$ 450.00
WEEK	\$ 1350.00
MONTH	\$ 4050.00

40' LIFT HEIGHT

4 WHEEL DRIVE

CODE 8844	
DAY	\$ 275.00
WEEK	\$ 825.00
MONTH	\$ 2475.00



SERVICED WEEKLY

CALL FOR EXACT SPECIFICATIONS

80' LIFT HEIGHT

4 WHEEL DRIVE

ARTICULATED

CODE 8885	
DAY	\$ 700.00
WEEK	\$ 2450.00
MONTH	\$ 7000.00

Platform Height30'
 Horizontal Outreach 53'
 Platform Capacity 500 lbs
 Overall Width 8'
 Stowed Length 36' 5"
 Stowed Height 9' 10"
 Weight 34,300 lbs



60' LIFT HEIGHT

2 WHEEL DRIVE

ARTICULATED

CODE 8865	
DAY	\$ 450.00
WEEK	\$ 1350.00
MONTH	\$ 4050.00

Platform Height60'
 Horizontal Outreach 39' 7"
 Platform Capacity 500 lbs
 Overall Width 8'
 Stowed Length 26' 5"
 Stowed Height 8' 5"
 Weight 20,700 lbs

BOOM LIFT



125' LIFT HEIGHT

**4 WHEEL DRIVE
ARTICULATED**

Platform Height125'
 Horizontal Outreach 63' 2"
 Platform Capacity 500 lbs
 Overall Width 8' 2"
 Stowed Length 37' 2"
 Stowed Height 10'
 Weight 44,000 lbs

Platform and Jib Rotation



CODE 8895	
DAY	\$ 2000.00
WEEK	\$ 6000.00
MONTH	\$ 12000.00

30' LIFT HEIGHT

ELECTRIC BOOM

Horizontal Outreach 20' 2"
 Platform Capacity 500 lbs
 Overall Width 48"
 Stowed Length 6' 7"
 Weight 15,300 lbs

Platform and Jib Rotation



CODE 8830	
DAY	\$ 250.00
WEEK	\$ 750.00
MONTH	\$ 1950.00

SCISSOR LIFTS

**ELECTRIC POWERED SCISSOR LIFTS
CALL FOR EXACT SPECIFICATIONS**



19' PLATFORM HEIGHT

CODE 8819	
DAY	\$ 125.00
WEEK	\$ 375.00
MONTH	\$ 750.00

26' PLATFORM HEIGHT

CODE 8826	
DAY	\$ 130.00
WEEK	\$ 390.00
MONTH	\$ 780.00



SCISSOR LIFTS

WIDE SELF PROPELLED SCISSOR LIFTS

**GAS OR
PROPANE POWERED**



**25' PLATFORM
HEIGHT**

CODE 8827	
DAY	\$ 140.00
WEEK	\$ 490.00
MONTH	\$ 1400.00

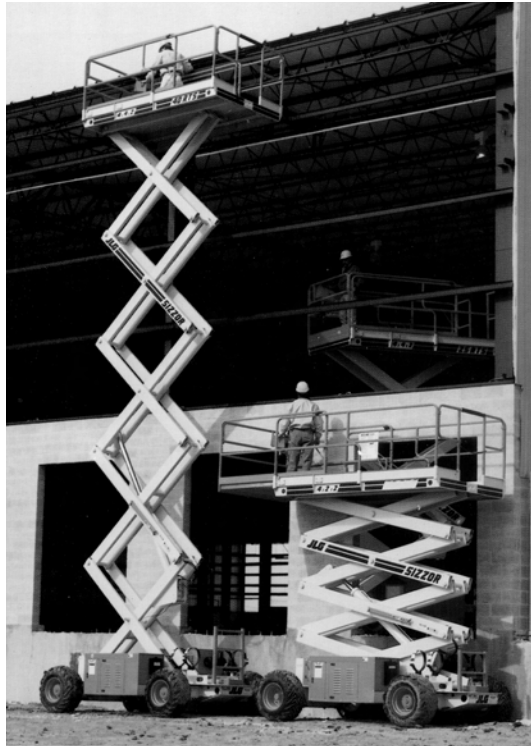

**40' PLATFORM
HEIGHT**

CODE 8841	
DAY	\$ 200.00
WEEK	\$ 700.00
MONTH	\$ 2000.00

GENIE 29' WORK PLATFORM



**THE PERFECT MACHINE FOR
THOSE HARD TO ACCESS JOBS.
WILL FIT THROUGH 4' X 4'
CEILING GRID**

**DESIGNED TO BE
EASILY LOADED
BY ONE MAN INTO
A PICKUP TRUCK**

- 29' PLATFORM HEIGHT
- 27" X 26" PLATFORM
- 350 LB. LIFT CAPACITY
- BASE - 56-59" LENGTH 29" WIDE
- AC PLUG IN

CODE 8829	
DAY	\$ 95.00
WEEK	\$ 332.50
MONTH	\$ 950.00

AIR COMPRESSORS



DIESEL POWERED AIR COMPRESSORS 185 CFM



CODE 0330	
4 HRS	\$ 40.00
DAY	\$ 55.00
WEEK	\$ 192.50
MONTH	\$ 550.00

COMPRESSOR PACKAGE

INCLUDES:

COMPRESSOR
HAMMER
50' HOSE
1 POINT & 1 CHISEL
(DOES NOT INCLUDE SPADE)

CODE 0330

4 HRS	\$ 73.00
DAY	\$ 88.00
WEEK	\$ 308.00
MONTH	\$ 828.00

PLUS FUEL

PORTABLE COMPRESSOR WITH DIESEL ENGINE- 375 CFM



CODE 0375	
DAY	\$ 110.00
WEEK	\$ 385.00
MONTH	\$ 1100.00

2) 3/4" AIR OUTLETS
1) 1 1/2" AIR OUTLET
RATED OPERATING PRESSURE 100 PSI
MAX OPERATING PRESSURE 120 PSI
112 H.P.



AIR COMPRESSOR TOOLS

PAVING BREAKER



CODE 0412	
DAY	\$ 20.00
WEEK	\$ 70.00
MONTH	\$ 200.00

35 LB. CLAY DIGGER



CODE 0414	
DAY	\$ 15.00
WEEK	\$ 52.50
MONTH	\$ 150.00

CHIPPING HAMMER



CODE 0418	
DAY	\$ 15.00
WEEK	\$ 52.50
MONTH	\$ 150.00

POST DRIVER



CODE 0450	
DAY	\$ 30.00
WEEK	\$ 105.00
MONTH	\$ 300.00

EDCO AIR SCRAPER

REMOVES FLOOR COVERINGS, TILE HARDENED CONCRETE, PLASTER, PAINT.

WT. 13 LBS.
LENGTH 5'



CODE 3215	
DAY	\$ 25.00
WEEK	\$ 87.50
MONTH	\$ 250.00



SINCE 1890
ACCESSORIES FOR

- PAVEMENT BREAKERS
- RIVET BUSTERS
- CHIPPING HAMMERS
- ROCK DRILLS
- CARBIDE TIPPED DRILLS
- ROCK BITS
- BOOM MOUNTED DEMOLITION TOOLS

ROCK DRILL

1" TO 3" BITS EXTRA



CODE 0476	
DAY	\$ 20.00
WEEK	\$ 70.00
MONTH	\$ 200.00

TAMPER 32 LB.



CODE 0425	
DAY	\$ 15.00
WEEK	\$ 52.50
MONTH	\$ 150.00

"PIERCE AIRROW" PNEUMATIC PIERCING TOOL.

THE PIERCE AIRROW IS THE IDEAL TOOL TO USE WHEN WORKING UNDER EXISTING ROADWAYS, SIDEWALKS AND DRIVEWAYS. IT ALLOWS THE PUSHING OF PIPE OR THE PULLING OF CABLE WITH NO DAMAGE TO THE ROAD SURFACE.

TOOL DIAMETER 3"
WEIGHT 75 LBS.
LENGTH 53"
UNIT COMES WITH 50' SUPPLY LINE AND OILER



MINIMUM OF 43 CFM AIR SUPPLY REQUIRED

CODE 0466	
DAY	\$ 150.00
WEEK	\$ 525.00
MONTH	\$ 1500.00

SANDBLASTERS



SANDBLAST EQUIPMENT

PORTABLE PRESSURE BLASTER

50' X 3/4" HOSE SUPPLIED
MOISTURE SEPARATOR
1/4" TUNGSTEN NOZZLE



150 LB SAND BLASTER

CODE 7315	
DAY	\$ 70.00
WEEK	\$ 245.00
MONTH	\$ 700.00

300 LB SAND BLASTER

CODE 7330	
DAY	\$ 70.00
WEEK	\$ 245.00
MONTH	\$ 700.00

PRICE DOES NOT INCLUDE COMPRESSOR

EXTRA HOSES

CODE 7331	
DAY	\$ 15.00
WEEK	\$ 52.00
MONTH	\$ 150.00

WE SELL
"BLACK BEAUTY"
SLAG



HAND HELD SAND BLASTER



CODE 0208	
DAY	\$ 10.00
WEEK	\$ 32.00
MONTH	\$ 60.00

SAND BLAST HELMET



LIGHT WEIGHT HELMET PROVIDES
COMFORT AND PROTECTION

CODE 7320	
DAY	\$ 5.00
WEEK	\$ 16.00
MONTH	\$ 30.00

STOP BUY ANY
OF OUR 5
LOCATIONS AND
SEE OUR COMPLETE
LINE OF SALE ITEMS



AIR HOOD PURIFIER

RESPIRATORY AIRLINE FILTER
AIR SUPPLIED HOOD W/25' HOSE
(MESA/NIOSH APPROVED)



CODE 7340	
DAY	\$ 15.00
WEEK	\$ 52.50
MONTH	\$ 150.00



CUTTING AND BRAZING OUTFIT

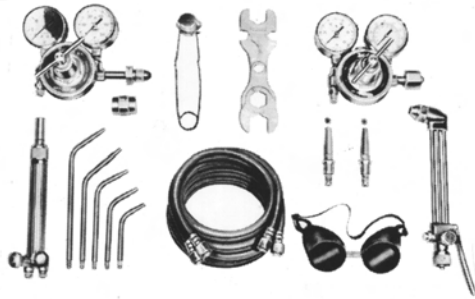

CODE 9416	
DAY	\$ 20.00
WEEK	\$ 64.00
MONTH	\$ 120.00

OXYGEN AND ACETYLENE EXTRA

WELDERS

WE SELL WELDING SUPPLIES

50' EXTENSION LEADS FOR WELDERS

CODE 9435	
DAY	\$ 7.50
WEEK	\$ 24.00
MONTH	\$ 45.00

WELDING HELMET

CODE 9430	
DAY	\$ 5.00
WEEK	\$ 16.00
MONTH	\$ 30.00

PORTABLE MIG WELDER

PLUGS IN THE WALL . . .

ALL-IN-ONE PORTABLE WELDER

120 V AC - EASY TO USE

WT. 69 LBS.

- 24 AMP DRAW
- .024-.035 WIRE REQUIREMENTS
- 1/8" METAL MAXIMUM THICKNESS



CODE 9404	
DAY	\$ 40.00
WEEK	\$ 140.00
MONTH	\$ 400.00

**30%
DUTY CYCLE
NOT FOR CONTINUOUS USE**

SPOOLS OF WIRE EXTRA

170 AMP DC WELDER 4000 WATT AC GENERATOR



CODE 9408	
DAY	\$ 45.00
WEEK	\$ 157.50
MONTH	\$ 450.00

The welder is a complete engine driven direct-arc welding machine. The diesel engine is connected to an electrical generator and mounted to a sturdy carrying frame.

TRAILER MOUNTED DIESEL WELDERS

CABLES EXTRA

300 AMP

10 K.W. GENERATOR



CODE 9410	
DAY	\$ 85.00
WEEK	\$ 297.00
MONTH	\$ 800.00



GENERATORS



ELECTRIC PLANTS FROM 2,400 TO 56,000 WATTS

Typical Motor Wattage

For motor-driven electric appliances and equipment such as refrigerators, air conditioners, pumps, furnace blowers, barn cleaners, sump pumps, check the typical motor wattage requirements listed in the chart below.

Motor HP Rating	Approx. Running Watts	Approximate Starting Watts			
		Universal Motors (Small appliance)	Repulsion Induction Motors	Capacitor Motors	Split Phase Motors
1/8	275	400	600	850	1200
1/4	400	500	850	1050	1700
1/3	450	600	975	1350	1950
1/2	600	750	1300	1800	2600
3/4	850	1000	1900	2600	X
1	1000	1250	2300	3000	X
1-1/2	1600	1750	3200	4200	X
2	2000	2350	3800	5100	X
3	3000	X	5200	6800	X



2.4 KW

6.0 KW

CODE 3402	
DAY	\$ 40.00
WEEK	\$ 140.00
MONTH	\$ 400.00

CODE 3405	
DAY	\$ 50.00
WEEK	\$ 175.00
MONTH	\$ 500.00

WE HAVE THE POWER !



25 KVA GENERATORS

70 KVA GENERATORS



VOLTAGE 3 PHASE: 208, 220, 240, 416, 440, 480V
VOLTAGE SINGLE PHASE: 120, 127, 139, 240, 254, 277V

AMPS	PHASE	VOLTAGE	WIRE
55.5	1	120	4
27.8	1	240	4
60	3	240	
30	3	480	

AMPS	PHASE	VOLTAGE	WIRE
155.5	1	120	4
77.8	1	240	4
168	3	240	
84	3	480	

CODE 3425	
DAY	\$ 115.00
WEEK	\$ 368.00
MONTH	\$ 690.00

**PRICES BASED ON AN 8 HR SHIFT WITHIN A 24HR PERIOD
DOUBLE SHIFT USE = 1 1/2 X RATE.
TRIPLE SHIFT USE = 2 X RATE .**

CODE 3450	
DAY	\$ 165.00
WEEK	\$ 528.00
MONTH	\$ 990.00



CONCRETE MIXERS & BRICK SAWS

GAS POWERED 10" BRICK SAW



CODE 7485	
DAY	\$ 85.00
WEEK	\$ 297.50
MONTH	\$ 850.00

**DIAMOND BLADE
INCLUDED**

14" GAS AND ELECTRIC POWERED BRICK SAWS

**DIAMOND BLADE
INCLUDED**

**CUTS BRICK,
BLOCK, PAVERS
AND STONE**



GAS POWERED

CODE 7487	
DAY	\$ 90.00
WEEK	\$ 315.00
MONTH	\$ 900.00

ELECTRIC POWERED

CODE 7489	
DAY	\$ 75.00
WEEK	\$ 262.50
MONTH	\$ 750.00

WE SELL A VARIETY OF DIAMOND AND COMPOSITE BLADES

ASPHALT CURBER

**FULLY ADJUSTABLE WHEEL ASSEMBLIES
AVERAGE SPEED 8' TO 15' PER MINUTE
EQUIPPED WITH 14 H.P. GASOLINE ENGINE
EXTRUDES FROM RIGHT OR LEFT SIDE
6' TURNING RADIUS WITH STANDARD LENGTH FORM**

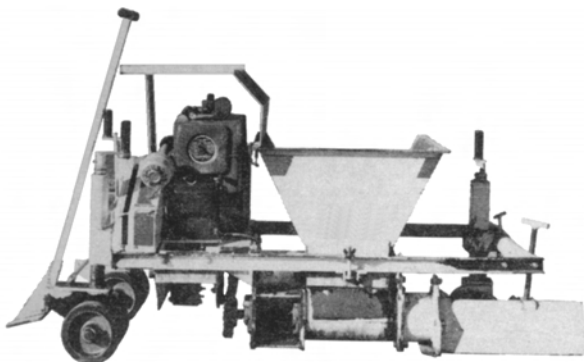

CODE 8620	
DAY	\$ 140.00
WEEK	\$ 490.00
MONTH	\$ 1250.00

CONCRETE MIXER ELECTRIC 4.3 CU. FT. CAPACITY, 1/2 BAG POWERFUL 1/2 HP, 115 VOLT

SWINGS 360°

**FAST EASY LOADING
AND DUMPING
QUIET OPERATION
DISMANTLES WITHOUT TOOLS**



CODE 1995	
DAY	\$ 20.00
WEEK	\$ 64.00
MONTH	\$ 120.00

CONCRETE MIXERS AND SAWS



CONCRETE MIXER GAS POWERED 9 CU. FT



CODE 1980	
DAY	\$ 60.00
WEEK	\$ 210.00
MONTH	\$ 600.00

MORTAR MIXER GAS POWERED 7 CU. FT. CAPACITY 3 BAG



CODE 1990	
DAY	\$ 60.00
WEEK	\$ 210.00
MONTH	\$ 600.00



WE CARRY CONCRETE SUPPLIES !

12" ELECTRIC CUT OFF SAW FOR CONCRETE OR STEEL

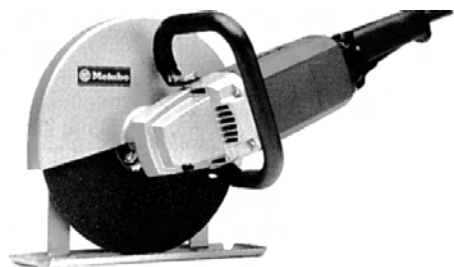

CODE 7410	
4 HRS	\$ 35.00
DAY	\$ 45.00
WEEK	\$ 144.50
MONTH	\$ 270.00

WE RENT DIAMOND BLADES

Double Insulated,
UL Listed, complies to OSHA

Specifications	Model 1333
Ratings	115V AC/DC
Amperage	15.0
No Load RPM	5,000
Spindle Thread	5/8" - 11NC
Length	18 1/2"
Weight	24 lbs.
Capacity	Depth of cut 3 1/2"

14" GAS MULTI- PURPOSE SAW

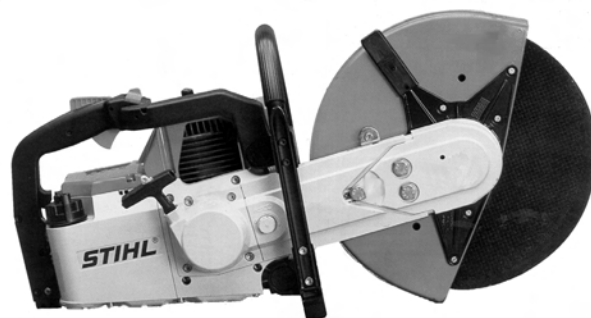

CODE 7413	
4 HRS	\$ 45.00
DAY	\$ 60.00
WEEK	\$ 210.00
MONTH	\$ 600.00

BLADES EXTRA



CONCRETE SAWS

**WE HAVE A LARGE SELECTION
OF BLADES FOR SALE**



CONCRETE CHAIN SAWS

GAS POWERED



BLADE NOT INCLUDED

CODE 7475	
DAY	\$ 125.00
WEEK	\$ 437.50
MONTH	\$ 1250.00

14" AIR POWERED CONCRETE SAW

CODE 7425	
DAY	\$ 55.00
WEEK	\$ 192.50
MONTH	\$ 550.00

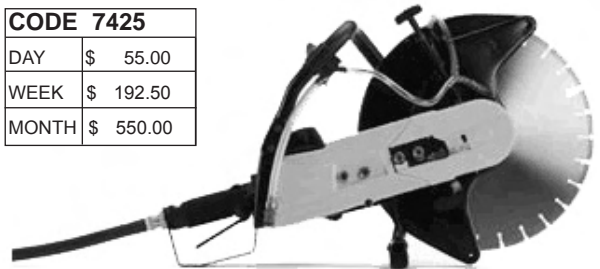

AIR POWERED SLAB SAW



**160 CFM REQUIRED
14" BLADE CAPACITY
4 3/4" CUTTING DEPTH
DIAMOND BLADE EXTRA**

CODE 7420	
DAY	\$ 55.00
WEEK	\$ 192.50
MONTH	\$ 550.00

TRAFFIC BARRICADES



CODE 0755	
DAY	\$ 5.00
WEEK	\$ 16.00
MONTH	\$ 30.00

36" CONES



CODE 0741	
DAY	\$ 3.00
WEEK	\$ 9.60
MONTH	\$ 18.00

ROAD SIGNS



CODE 0765	
DAY	\$ 7.50
WEEK	\$ 24.00
MONTH	\$ 45.00

Safety Fence, Caution Tape, etc.. also available

CONCRETE EQUIPMENT



SLAB SAWS
**USED FOR CUTTING EXPANSION JOINTS, INSTALLING TRAFFIC LOOPS,
 REPAIRING ROADS OR REMOVING SLABS**

MANUAL CONCRETE SAW
11 HP.
12" OR 14" BLADE CAPACITY
4 3/4" MAX. CUTTING DEPTH

SELF-PROPELLED CONCRETE SAW
18 HP.
14" OR 18" BLADE CAPACITY
6 3/4" MAX. CUTTING DEPTH

LARGE SELF-PROPELLED CONCRETE SAW
35 HP.
24" BLADE CAPACITY
9 3/4" MAX. CUTTING DEPTH



CODE 7414	
DAY	\$ 60.00
WEEK	\$ 210.00
MONTH	\$ 600.00

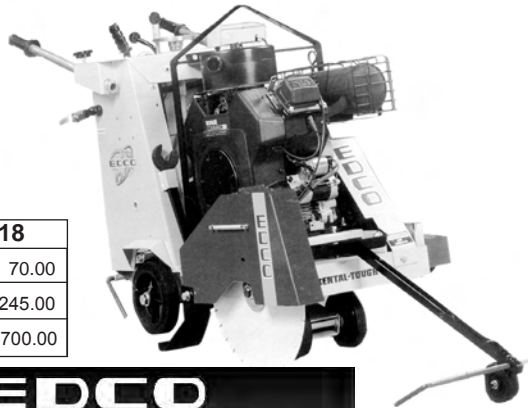

CODE 7418	
DAY	\$ 70.00
WEEK	\$ 245.00
MONTH	\$ 700.00



Concrete Solutions for Concrete Problems

CODE 7424	
DAY	\$ 110.00
WEEK	\$ 385.00
MONTH	\$ 1100.00

BLADES EXTRA

ASPHALT OR CONCRETE SCARIFIERS / PLANES
HIGH PRODUCTION CONCRETE OR ASPHALT SCARIFIERS FOR GROOVING DAIRY BARN, ELIMINATING HIGH OR UNEVEN SPOTS, CREATING NON-SLIP FLOORS, REMOVING OLD COATINGS, TEXTURING SURFACES OR REMOVING UP TO 3/4" OF MATERIAL

MANUAL CONCRETE PLANE

8" CUTTING PATH

10" CUTTING PATH

HEAVY DUTY SELF-PROPELLED CONCRETE PLANE



CODE 7415	
DAY	\$ 125.00
WEEK	\$ 437.50
MONTH	\$ 1250.00

TEETH AVAILABLE FOR RENT OR SALE

CUTTERS EXTRA

TEXTURES

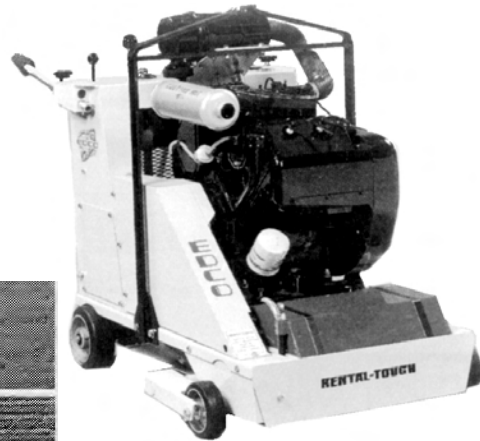
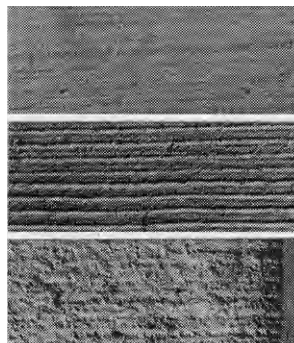

CODE 7450	
DAY	\$ 150.00
WEEK	\$ 525.00
MONTH	\$ 1500.00

TEETH AVAILABLE FOR SALE



CONCRETE EQUIPMENT

EDCO CONCRETE GRINDERS

USE TO REMOVE TRAVEL MARKS, HIGH SPOTS, PAINTS, RAIN SPOTS. CLEANS BUILDUP OF HARDENED DEBRIS.



WE CARRY STONES, SCARIFIERS, DYMA-SERTS AND STRIP-SERTS !

ELECTRIC

110/220 V
SWITCHABLE

CODE 3720	
DAY	\$ 55.00
WEEK	\$ 192.50
MONTH	\$ 550.00

GAS

7 HP

CODE 3725	
DAY	\$ 60.00
WEEK	\$ 210.00
MONTH	\$ 600.00

CONCRETE POLISHER

ELECTRIC



PRICE DOES NOT INCLUDE
POLISHING ATTACHMENTS

CODE 3760	
DAY	\$ 300.00
WEEK	\$ 1200.00
MONTH	\$ 3000.00

LASER LEVEL

HORIZONTAL APPLICATIONS:
FLOOR AND CEILINGS

VERTICAL APPLICATIONS:
DRYWALL, CURTAINS, WALLS AND MORE



CODE 5835	
DAY	\$ 80.00
WEEK	\$ 280.00
MONTH	\$ 800.00

BUILDERS LEVEL & TRANSIT

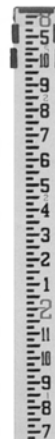

TRANSIT

CODE 5820	
DAY	\$ 30.00
WEEK	\$ 96.00
MONTH	\$ 180.00

LEVEL

CODE 5818	
DAY	\$ 25.00
WEEK	\$ 80.00
MONTH	\$ 150.00

CONCRETE, ASPHALT EQUIPMENT



ELECTRIC BREAKER

INCLUDES POINT & CHISEL
65 LBS. 110.V



REQUIRES MIN.
12 GAUGE
EXTENSION
CORD 50' MAX.

CODE 8378	
4 HRS	\$ 40.00
DAY	\$ 60.00
WEEK	\$ 210.00
MONTH	\$ 600.00

GASOLINE BREAKER



INCLUDES POINT & CHISEL

CODE 8376	
4 HRS	\$ 55.00
DAY	\$ 80.00
WEEK	\$ 280.00
MONTH	\$ 800.00

WALK BEHIND BROOM

13 HP ENGINE



46 INCH BROOM WIDTH

CODE 8756	
4 HRS	\$ 50.00
DAY	\$ 75.00
WEEK	\$ 262.50
MONTH	\$ 750.00

MEASURING WHEEL



CODE 5840	
DAY	\$ 10.00
WEEK	\$ 32.00
MONTH	\$ 90.00



ELECTRIC HAMMERS & DRILLS



ELECTRIC ROTARY HAMMER

DRILLS HOLES IN CONCRETE
3/8" TO 2"

REQUIRES MIN. 12 GAUGE EXTENSION CORD 50' MAX.

SOLID BITS

CODE 2716	
4 HRS	\$ 25.00
DAY	\$ 45.00
WEEK	\$ 157.50
MONTH	\$ 450.00

CODE	DAY	SIZE
2717	\$ 4.00	UP TO 1"
2718	\$ 15.00	1" TO 1 1/2"
2719	\$ 20.00	1 1/2" TO 2"

SMALL ELECTRIC DEMO HAMMER

POINT AND CHISEL INCLUDED



REQUIRES MIN. 12 GAUGE EXTENSION CORD 50' MAX.

Rating 120V
 Amperage 12.8
 No Load BPM 850-1800
 Impact Energy (ft.lbs.) 4.0-16.5
 Weight (lbs.) 22
 Cord Length (ft.) 12

CODE 8380	
4 HRS	\$ 25.00
DAY	\$ 45.00
WEEK	\$ 157.50
MONTH	\$ 450.00

DIAMOND CORE DRILLS



CODE 2724	
DAY	\$ 90.00
WEEK	\$ 315.00
MONTH	\$ 540.00

BITS RENTAL RATES

CODE	DAY	SIZE
2725	\$ 30.00	1-1.5"
2726	\$ 50.00	2-2.5"
2727	\$ 60.00	3-3.5"
2728	\$ 75.00	4-4.5"
2729	\$ 105.00	5-6"
2730	\$ 175.00	THRU 10"



HAND HELD CORE DRILL



UP TO 3" BIT

CODE 2722	
DAY	\$ 90.00
WEEK	\$ 315.00
MONTH	\$ 540.00

CONCRETE TOOLS



9" HEAVY DUTY ANGLE GRINDER



CODE 3750	
DAY	\$ 20.00
WEEK	\$ 64.00
MONTH	\$ 120.00

CODE 9700	
3750	CUPSTONE
3752	BRUSH
3751	WHEEL



4 1/2" ANGLE GRINDER



DIAMOND TUCK POINT BLADES AVAILABLE

CODE 3740	
DAY	\$ 15.00
WEEK	\$ 48.00
MONTH	\$ 90.00

REBAR CUTTER/ BENDER 5/8" CAPACITY

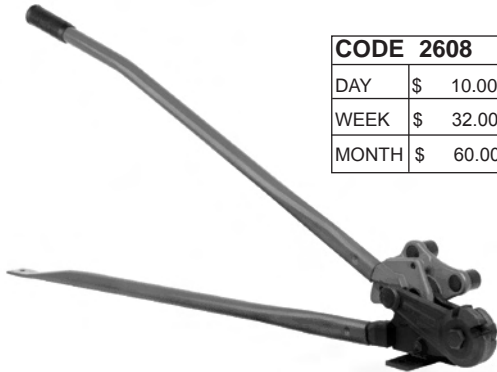

CODE 2608	
DAY	\$ 10.00
WEEK	\$ 32.00
MONTH	\$ 60.00

MAGNETIC SWEEPER

24" WIDTH



CODE 5130	
DAY	\$ 15.00
WEEK	\$ 48.00
MONTH	\$ 150.00

CONCRETE BUCKETS 1 CU. YARD

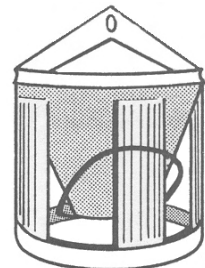

CODE 2010	
DAY	\$ 35.00
WEEK	\$ 122.50
MONTH	\$ 350.00

ELECTRIC CONCRETE VIBRATORS SEVERAL HEAD SIZES



CODE 1914	
DAY	\$ 40.00
WEEK	\$ 140.00
MONTH	\$ 240.00

BULL FLOAT INCLUDES 2 HANDLES 6' LENGTH

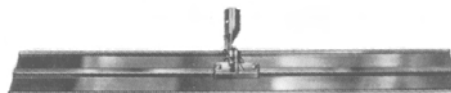

CODE 2020	
DAY	\$ 15.00
WEEK	\$ 48.00
MONTH	\$ 90.00

CHUTES 12' LONG ALUMINUM CHUTE



CODE 2012	
DAY	\$ 20.00
WEEK	\$ 64.00
MONTH	\$ 120.00



**RIDE ON MOTORIZED
GEORGIA BUGGIES**

Wheelbase 38" Capacity56 cu.yd.
 Overall Width 44" Speed 7 Mph.
 Weight Capacity ... 2600 lbs. Dump Control Hydraulic
 Operating Weight .. 725 lbs.



FOAM FILLED TIRES "NO FLATS"

CODE 1925	
DAY	\$ 95.00
WEEK	\$ 332.50
MONTH	\$ 950.00

CONCRETE TOOLS

**GEORGIA BUGGIES
6 CU. FOOT CAPACITY**

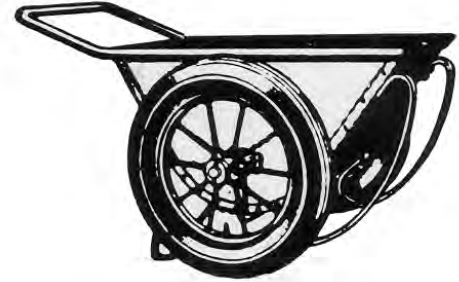

CODE 1930	
DAY	\$ 15.00
WEEK	\$ 48.00
MONTH	\$ 90.00

**GASTROWELING MACHINES
36" AND 48"**

**"FLOAT AND FINISH
WITH THE SAME BLADES"**

ELECTRIC ALSO AVAILABLE



**WHEEL BARROW
5 CU. FOOT CAPACITY**

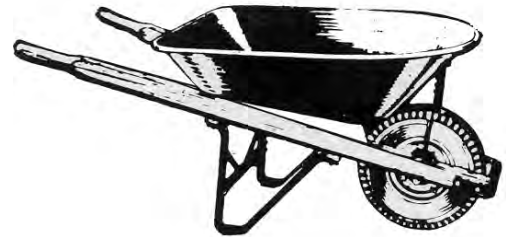

36"

CODE 1940	
DAY	\$ 55.00
WEEK	\$ 192.50
MONTH	\$ 550.00



48"

CODE 1948	
DAY	\$ 65.00
WEEK	\$ 227.50
MONTH	\$ 650.00

CODE 1920	
DAY	\$ 8.00
WEEK	\$ 25.60
MONTH	\$ 48.00

RIDE-ON POWER TROWEL

**ENGINE 20 HP
WEIGHT 1096 LBS
TWIN PITCH CONTROL
72" PATH
36" NON OVERLAPPING BLADES**

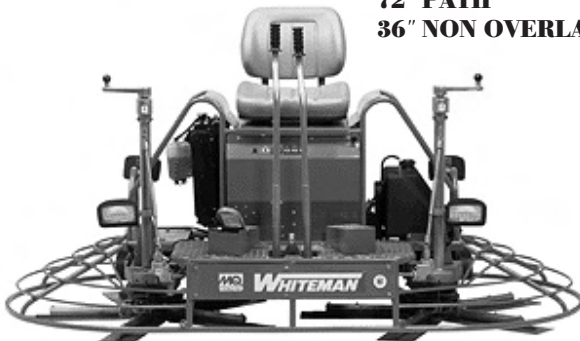

CODE 1950	
DAY	\$ 175.00
WEEK	\$ 612.50
MONTH	\$ 1750.00

WET SCREED



10' WIDTH

CODE 1935	
4 HRS	\$ 40.00
DAY	\$ 60.00
WEEK	\$ 210.00
MONTH	\$ 400.00

HEATERS



MASTER KEROSENE/DIESEL FIRED HEATERS

HOW TO FIND THE RIGHT SIZE HEATER FOR YOU WORKSPACE

First, determine the cubic feet of the area you will heat.

Use the formula: Length x Width x Height. For example
 $28' \times 25' \times 10' = 7,000 \text{ cu. ft.}$

Next, decide the typical heat rise you'll require. For example, if the room temperature, unheated, drops to 15 degrees F and you want it heated to 70 degrees F, the heat rise requirement is 70 degrees minus 15 degrees = 55 degrees.

Then use this formula: (sample numbers inserted)
 $7,000 \text{ cu. ft.} \times 0.133 \text{ (constant)} \times 55 \text{ degrees (temperature rise)} = 51,205 \text{ Btu per hour required.}$

320,000 BTU



155,000 BTU



CODE 3836	
DAY	\$ 40.00
WEEK	\$ 140.00
MONTH	\$ 400.00

CODE 3840	
DAY	\$ 75.00
WEEK	\$ 262.50
MONTH	\$ 750.00

UTILITY SPACE HEATERS



**1500 W
115 VOLT**

CODE 3828	
DAY	\$ 6.00
WEEK	\$ 19.20
MONTH	\$ 36.00

INFRA-RED HEATERS

NO ELECTRICITY NEEDED

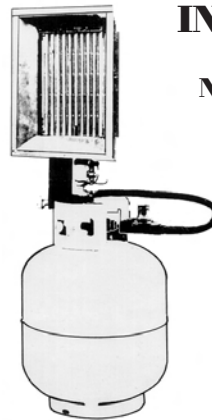

TANKS AVAILABLE

CODE 3832	
DAY	\$ 15.00
WEEK	\$ 48.00
MONTH	\$ 90.00

**SPACE HEATER
150,000 BTU 115V
PROPANE FUEL AVAILABLE**



CODE 3830	
DAY	\$ 30.00
WEEK	\$ 96.00
MONTH	\$ 180.00

**SALAMANDER
SPACE HEATER**

**PROPANE
AVAILABLE
NO ELECTRICITY
NEEDED**



250,000 BTU

**100%
SAFETY
CONTROL**

CODE 3834	
DAY	\$ 15.00
WEEK	\$ 48.00
MONTH	\$ 90.00



DEHUMIDIFIERS AND FANS

BUILDING DRYER AND DEHUMIDIFIER



**HIGH CAPACITY
LOW TEMPERATURE
DEHUMIDIFIERS**

**1 HORSEPOWER
VOLTS: 115 AMPS: 15
HEIGHT: 29" WIDTH 20"
DEPTH 24"
BTU/HR: 5600**

CODE 3843	
DAY	\$ 45.00
WEEK	\$ 157.50
MONTH	\$ 270.00

SMALL DEHUMIDIFIER



**25 PINT
CAPACITY**

CODE 3842	
DAY	\$ 15.00
WEEK	\$ 48.00
MONTH	\$ 90.00

24" PEDESTAL FAN



**BLADE SIZE 24"
4400 CFM
1070 RPM
78 LBS. WT.**

CODE 3814	
DAY	\$ 15.00
WEEK	\$ 45.00
MONTH	\$ 90.00

42" FANS

**1 HP 330 RPM
22,700 CFM**

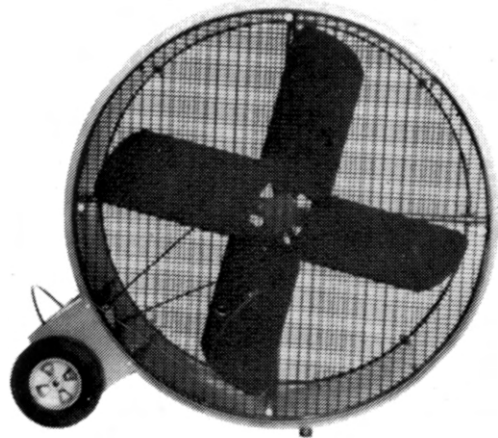

CODE 3848	
DAY	\$ 55.00
WEEK	\$ 192.50
MONTH	\$ 330.00

PORTABLE VENTILATING BLOWERS



**HOSE
8" X 15 FT**

HOSES EXTRA

CODE 3850	
DAY	\$ 25.00
WEEK	\$ 80.00
MONTH	\$ 150.00

TWO SECTIONS OF HOSE MAXIMUM

AIR PURIFIER NEGATIVE-POSITIVE ION GENERATOR

"OZONE MACHINE"

**Removes:
Smoke • Pet odor • Stale air • Mold-Mildew,
Pollen, And much more... Unlimited Applications !**



CODE 4618	
DAY	\$ 30.00
WEEK	\$ 96.00
MONTH	\$ 180.00

PRESSURE WASHERS HOT / COLD



1000 PSI 210° F

CODE 7355	
DAY	\$ 100.00
WEEK	\$ 350.00
MONTH	\$ 1000.00

HOT WATER CLEANERS



**3000 PSI
SELF CONTAINED
TRAILER MOUNTED
ADJUSTABLE HEAT CONTROL**

CODE 7370	
DAY	\$ 140.00
WEEK	\$ 490.00
MONTH	\$ 1400.00



Mi-T-M CORPORATION

ELECTRIC PRESSURE WASHERS

**ONLY 43 LBS. 1200 PSI
24 FOOT PRESSURE HOSE
STANDARD HOUSEHOLD CURRENT**

**GREAT FOR SMALL DECKS
CONDO'S, SIDEWALKS,
GRILLS..... ALL SMALL
CLEANING JOBS**

CODE 8128	
4 HRS	\$ 25.00
DAY	\$ 40.00
WEEK	\$ 128.00
MONTH	\$ 240.00



PRESSURE WASHERS



2700 PSI

CODE 7360	
4 HRS	\$ 55.00
DAY	\$ 75.00
WEEK	\$ 262.50
MONTH	\$ 750.00

3500 PSI

CODE 7335	
4 HRS	\$ 65.00
DAY	\$ 90.00
WEEK	\$ 315.00
MONTH	\$ 900.00

**EXTENSION
WAND
7' TO 18'**

CODE 7354	
DAY	\$ 15.00
WEEK	\$ 48.00
MONTH	\$ 90.00

**SAND INJECTOR FOR
WET BLASTING**

CODE 7362	
DAY	\$ 15.00
WEEK	\$ 48.00
MONTH	\$ 90.00

CHEMICAL INJECTOR

CODE 7363	
DAY	\$ 5.00
WEEK	\$ 16.00
MONTH	\$ 30.00



**COMES WITH 50' HOSE
GUN AND NOZZLES**

Cleaning Chemicals Available



SCAFFOLDING

BIL-JAX A STEP ABOVE®

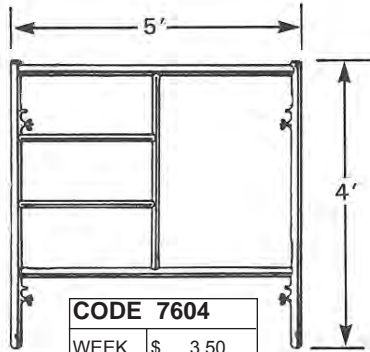

CODE 7604	
WEEK	\$ 3.50
MONTH	\$ 10.50

CROSS BRACE



CODE 7608	
WEEK	\$ 2.00
MONTH	\$ 6.00

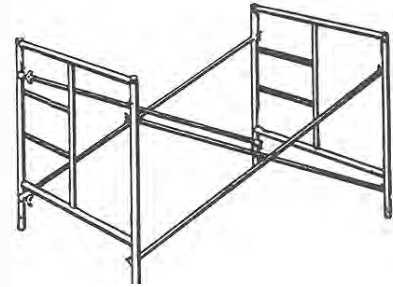

4' HIGH 5' WIDE 7' LONG

TYPICAL SECTION

2 - 4' X 5' ENDS
2 - CROSS BRACES

OUTRIGGERS

CODE 7615	
WEEK	\$ 2.00
MONTH	\$ 6.00

NARROW SCAFFOLDING



CODE 7606 / 7608	
SINGLE UNIT	
WEEK	\$ 28.00
MONTH	\$ 84.00

28" Wide.

BRICKLAYERS SCAFFOLD

OPEN TYPE

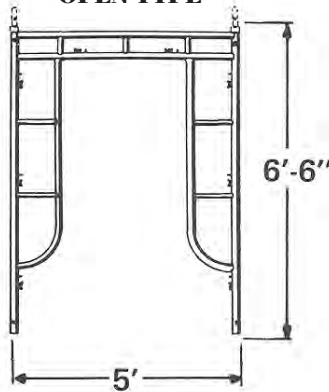

CODE 7607	
WEEK	\$ 4.00
MONTH	\$ 12.00

CATWALK

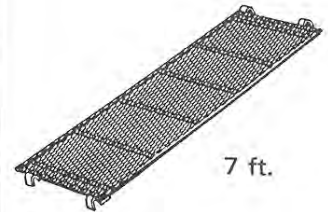

CODE 7610	
WEEK	\$ 6.00
MONTH	\$ 18.00

SCAFFOLD GUARD RAILS

CODE 7622	
WEEK	\$ 1.00
MONTH	\$ 3.00

SCAFFOLD GUARD POSTS

CODE 7620	
WEEK	\$ 1.50
MONTH	\$ 4.50

SAFETY POST AND GUARD RAILS ARE MANDATORY

SHORING POSTS TWO SIZES

SHORT
MIN HT. : 2'
MAX HT. : 3'1"
CAPACITY 3,500 LBS
WEIGHT : 12 LBS

LONG
MIN HT. : 6' 11"
MAX HT. : 11' 4"
CAPACITY: 5,000 LBS
WEIGHT: 28.5 LBS



CODE	
2049	2048
	SHORT LONG
DAY	\$ 5.00 \$ 5.00
WEEK	\$ 15.00 \$ 15.00
MONTH	\$ 45.00 \$ 45.00

WHEELS



CODE 7612	
WEEK	\$ 3.50
MONTH	\$ 10.50

SIDE BRACKET

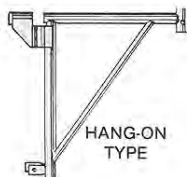

CODE 7618	
WEEK	\$ 2.00
MONTH	\$ 6.00

LEVELING JACK

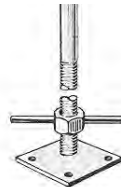

CODE 7628	
WEEK	\$ 2.50
MONTH	\$ 7.50

PAINT & WATERPROOFING



ELECTRIC AIRLESS PAINT SPRAYER



CODE 6288	
4 HRS	\$ 50.00
DAY	\$ 80.00
WEEK	\$ 280.00
MONTH	\$ 800.00

GASOLINE AIRLESS PAINT SPRAYER

3.5 HP



CODE 6284	
DAY	\$ 110.00
WEEK	\$ 385.00
MONTH	\$ 1100.00

SUPER STRIPER SUPER STRIPER WITH ADJUSTABLE SPRAY WIDTH 1" TO 4 1/2"



PAINT EXTRA

CODE 6258	
DAY	\$ 15.00
WEEK	\$ 48.00
MONTH	\$ 90.00

SPRAYS PATTERN PISTOL ACOUSTIC PLASTERS WATERPROOFING COMPOUNDS AND PAINTS



CODE 6290	
DAY	\$ 15.00
WEEK	\$ 48.00
MONTH	\$ 90.00

WALLPAPER STEAMER



CODE 6280	
DAY	\$ 15.00
WEEK	\$ 48.00
MONTH	\$ 90.00

INSULATION BLOWER

**100 FEET OF HOSE
HOPPER HOLDS 25 LBS
OF INSULATION**



CODE 3865	
4 HRS	\$ 40.00
DAY	\$ 60.00
WEEK	\$ 210.00
MONTH	\$ 600.00



**SUBMERSIBLE PUMP
WITH 50' HOSE**



**2" SUBMERSIBLE
TRASH PUMP
34' HEAD 4,320 GPH
OUTPUT**

CODE 7090	
DAY	\$ 35.00
WEEK	\$ 112.00
MONTH	\$ 210.00

WASHDOWN



HOSE

CODE 7081	
DAY	\$ 10.00
WEEK	\$ 32.00
MONTH	\$ 60.00

NOZZLE

CODE 7082	
DAY	\$ 5.00
WEEK	\$ 16.00
MONTH	\$ 30.00

PUMPS

**LO LEVEL
PUMPS**



CODE 7016	
4 HRS	\$ 9.00
DAY	\$ 15.00
WEEK	\$ 48.00
MONTH	\$ 90.00

**UTILITY PUMP
GREAT FOR
WATER BEDS**

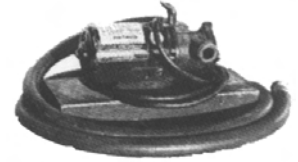

CODE 7017	
DAY	\$ 10.00
WEEK	\$ 32.00
MONTH	\$ 60.00

**2" TRASH PUMP
12,000 GPH GAS POWERED
INCLUDES 20' OF SUCTION &
50' OF DISCHARGE HOSE**

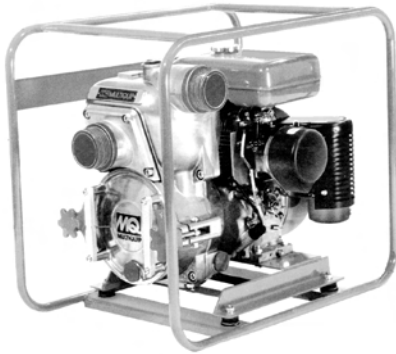

CODE 7062	
DAY	\$ 50.00
WEEK	\$ 175.00
MONTH	\$ 500.00

**3" DIAPHRAGM PUMP
3,600 GPH GAS POWERED
INCLUDES 20' OF SUCTION &
50' OF DISCHARGE HOSE**

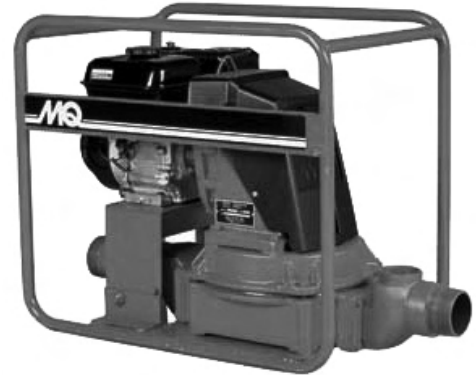

CODE 7074	
DAY	\$ 55.00
WEEK	\$ 192.50
MONTH	\$ 550.00



**3" TRASH PUMP
25,000 GPH GAS POWERED
INCLUDES 20' OF SUCTION &
50' OF DISCHARGE HOSE**

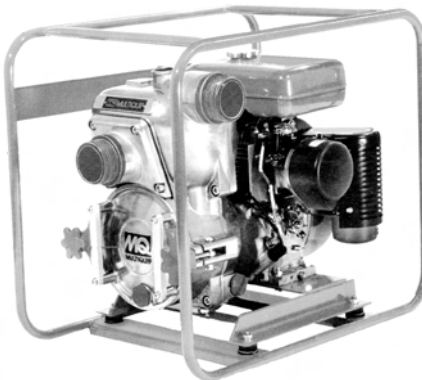

CODE 7064	
DAY	\$ 65.00
WEEK	\$ 227.50
MONTH	\$ 650.00

**4" TRASH PUMP
36,000 GPH GAS POWERED
INCLUDES 20' OF SUCTION &
50' OF DISCHARGE HOSE**

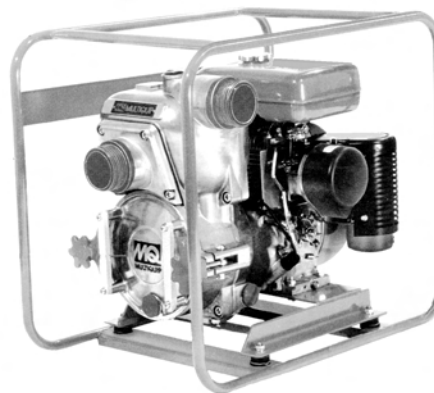

CODE 7065	
DAY	\$ 80.00
WEEK	\$ 280.00
MONTH	\$ 800.00

SEWER SNAKES



EASY ROOTER ELECTRIC SNAKE



FOR 3" TO 6" LINES

75' CABLE

CODE 6828	
4 HRS	\$ 50.00
DAY	\$ 75.00
WEEK	\$ 262.50
MONTH	\$ 750.00

ELECTRIC HAND HELD SNAKE

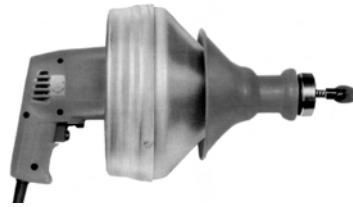

**30' OF CABLE FOR
1 1/2" TO 2 1/2" DRAINS**

CODE 6816	
4 HRS	\$ 20.00
DAY	\$ 35.00
WEEK	\$ 112.00
MONTH	\$ 210.00

50' ELECTRIC SNAKE

**50' CABLE FOR
1 1/2" TO 2 1/2" LINES**



CODE 6820	
4 HRS	\$ 30.00
DAY	\$ 45.00
WEEK	\$ 144.00
MONTH	\$ 270.00

20 TON HYDRAULIC PIPE BENDER

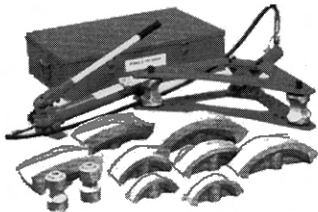

**BENDS 1/2" TO 2"
STEEL PIPE**

CODE 6716	
DAY	\$ 55.00
WEEK	\$ 192.50
MONTH	\$ 330.00

CYCLONE CONDUIT BENDER

**BENDS 1/2", 3/4", 1", 1 1/4", 1 1/2", 2" STEEL AND
ALUMINUM RIDGID I.M.C. AND E.M.T CONDUIT
... ALL ON ONE SHOE.
ALSO BENDS 1/2" - 1 1/2" P.V.C. COATED CONDUIT**



CODE 6715	
DAY	\$ 100.00
WEEK	\$ 350.00
MONTH	\$ 600.00

HAND SNAKE

**50' CABLE FOR
1 1/2" TO 2 1/2" LINES**

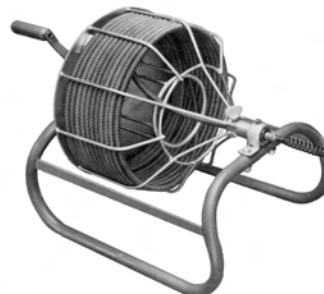

CODE 6814	
DAY	\$ 15.00
WEEK	\$ 48.00
MONTH	\$ 90.00



PLUMBERS TOOLS

PIPE WRENCHES



CODE 6751	
DAY	\$ 5.00
WEEK	\$ 16.00
MONTH	\$ 30.00

PIPE CUTTERS THRU 2"

CODE 6720	
DAY	\$ 5.00
WEEK	\$ 16.00
MONTH	\$ 30.00



PIPE THREADER



CODE 6766	
4 HRS	\$ 25.00
DAY	\$ 40.00
WEEK	\$ 140.00
MONTH	\$ 400.00

SOIL PIPE CUTTER



CODE 6825	
DAY	\$ 15.00
WEEK	\$ 48.00
MONTH	\$ 90.00

PIPE VISES



CODE 6860	
DAY	\$ 10.00
WEEK	\$ 32.00
MONTH	\$ 60.00

SIZES: 1/8" TO 5" PIPE

RIDGID 300 POWER DRIVER

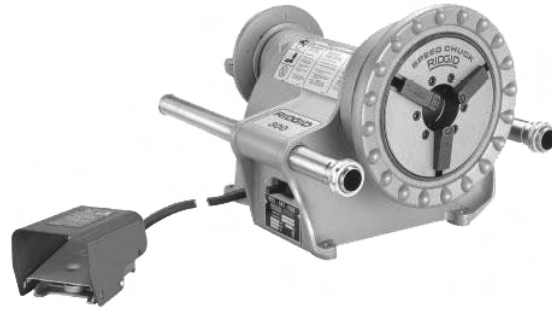

POWER VISE ACCESSORIES KIT

CODE 6863	
DAY	\$ 35.00
WEEK	\$ 122.50
MONTH	\$ 350.00

CODE 6864	
DAY	\$ 45.00
WEEK	\$ 157.50
MONTH	\$ 450.00

PIPE CUTTER THRU 4"



CODE 6722	
DAY	\$ 10.00
WEEK	\$ 32.00
MONTH	\$ 60.00

AUTOMATIC THREADING MACHINES

EQUIPPED WITH STAND
AUTOMATIC THROUGH THE HEAD OILING
SYSTEM FED BY A SELF PRIMING PUMP,
CUTTER DESIGNED FOR SPEED AND ACCURACY
AND ONE STEP REAMING ACTION- ALL
PROVIDE EASY, TROUBLE FREE OPERATION



CODE 6880	
DAY	\$ 80.00
WEEK	\$ 280.00
MONTH	\$ 800.00

PIPE THREADING DIES



CODE 6840	
DAY	\$ 20.00
WEEK	\$ 70.00
MONTH	\$ 200.00

DIES 1/2" TO 2" PIPE

RENTAL OVER 1 WEEK
MUST PURCHASE DIES

WE SELL GLOVES !



BAND SAW



BLADES EXTRA

CODE 7406	
DAY	\$ 25.00
WEEK	\$ 80.00
MONTH	\$ 150.00

7 1/4" AND 16" CIRCULAR SAWS

7 1/4"



BLADE INCLUDED

CODE 7419	
4 HRS	\$ 9.00
DAY	\$ 15.00
WEEK	\$ 48.00
MONTH	\$ 90.00

16"

CODE 7416	
4 HRS	\$ 20.00
DAY	\$ 35.00
WEEK	\$ 112.00
MONTH	\$ 210.00

12" AND 14" HIGH SPEED CHOP SAW



CODE 7460	
DAY	\$ 15.00
WEEK	\$ 48.00
MONTH	\$ 90.00

BLADES EXTRA

POWER TOOLS



TIGER SAW



BLADES EXTRA

CODE 7459	
4 HRS	\$ 12.00
DAY	\$ 20.00
WEEK	\$ 64.00
MONTH	\$ 120.00

JIG SAWS



BLADES EXTRA

CODE 7432	
4 HRS	\$ 9.00
DAY	\$ 15.00
WEEK	\$ 45.00
MONTH	\$ 90.00

12" COMPOUND MITRE BOX SAW



BLADE INCLUDED

CODE 7446	
DAY	\$ 35.00
WEEK	\$ 112.00
MONTH	\$ 210.00



Large Selection of Hardware Items For Sale



ELECTRIC POWER TOOLS

MITRE BOX SAW

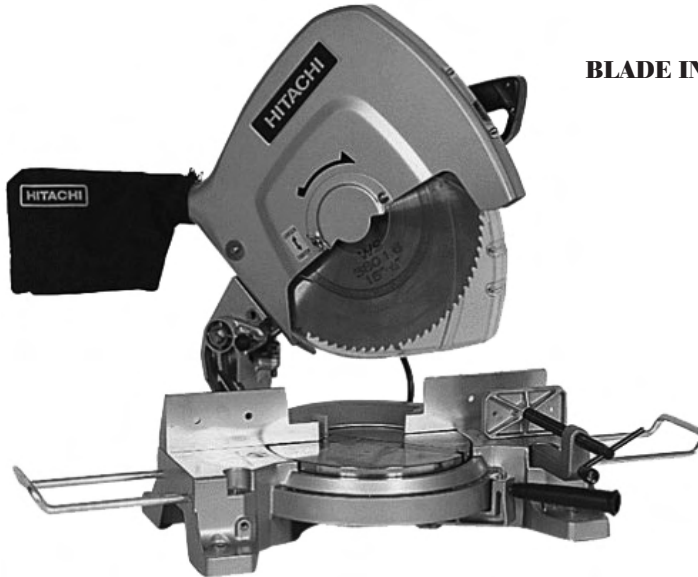

BLADE INCLUDED

15" INCH

CODE 7445	
DAY	\$ 35.00
WEEK	\$ 112.00
MONTH	\$ 210.00

DRYWALL GUN



CODE 8354	
DAY	\$ 15.00
WEEK	\$ 48.00
MONTH	\$ 90.00

REVERSIBLE 1/2" AND 3/4" DRILL MOTORS



CODE 2776 1/2"	
CODE 2780 3/4"	
4 HRS	\$ 9.00
DAY	\$ 15.00
WEEK	\$ 48.00
MONTH	\$ 90.00

1/2" RIGHT ANGLE DRILL



CODE 2756	
4 HRS	\$ 9.00
DAY	\$ 15.00
WEEK	\$ 48.00
MONTH	\$ 90.00

SHORTY DRILL



CODE 1065 1/4"	
CODE 1066 3/8"	
4 HRS	\$ 9.00
DAY	\$ 15.00
WEEK	\$ 48.00
MONTH	\$ 90.00

ELECTRIC POWER TOOLS



ROTARY HAMMER



1/2"

CODE 2720	
4 HRS	\$ 12.00
DAY	\$ 20.00
WEEK	\$ 64.00
MONTH	\$ 120.00

3/4"

CODE 2758	
DAY	\$ 20.00
WEEK	\$ 64.00
MONTH	\$ 120.00

**WE SELL
DRILL BITS !**

BELT SANDER



CODE 8344	
4 HRS	\$ 9.00
DAY	\$ 15.00
WEEK	\$ 48.00
MONTH	\$ 90.00

FINISHING SANDER



CODE 8340	
4 HRS	\$ 6.00
DAY	\$ 10.00
WEEK	\$ 32.00
MONTH	\$ 60.00

ROUTER



CODE 6550	
4 HRS	\$ 12.00
DAY	\$ 20.00
WEEK	\$ 64.00
MONTH	\$ 120.00

CAR POLISHER



CODE 1212	
4 HRS	\$ 6.00
DAY	\$ 10.00
WEEK	\$ 32.00
MONTH	\$ 60.00

**WE SELL
BUFFING PADS !**



ELECTRIC POWER TOOLS

DOOR PLANE

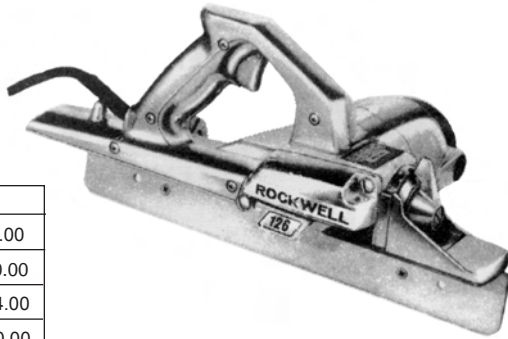

CODE 8326
4 HRS \$ 12.00
DAY \$ 20.00
WEEK \$ 64.00
MONTH \$ 120.00

BLOCK PLANE



CODE 8327
4 HRS \$ 9.00
DAY \$ 15.00
WEEK \$ 48.00
MONTH \$ 90.00

14 GAUGE NIBBLER



Maximum Capacity :
 mild steel - 14 ga, stainless -16ga
 minimum cutting radius : 3/16"
 amps : 5.2
 strokes per min. (no load): 3000
 weight : 4.5 lbs
 length : 11"

CODE 2625
DAY \$ 20.00
WEEK \$ 64.00
MONTH \$ 120.00

12 GAUGE SHEAR



Maximum Capacity :
 mild steel - 12 ga, stainless -14ga
 minimum cutting radius : 3/4"
 amps : 5.2
 strokes per min. (no load): 3000
 weight : 5.0 lbs
 length : 11"

CODE 2645
DAY \$ 25.00
WEEK \$ 80.00
MONTH \$ 150.00

MAGNETIC DRILL PRESS



CODE 2790
DAY \$ 50.00
WEEK \$ 160.00
MONTH \$ 300.00



Bits, Blades, Nails for Sale

HEAT GUN



CODE 6295
DAY \$ 10.00
WEEK \$ 32.00
MONTH \$ 60.00

AIR TOOLS



GAS AND ELECTRIC COMPRESSORS



1 1/2 HP ELECTRIC

CODE 0204	
DAY	\$ 35.00
WEEK	\$ 112.00
MONTH	\$ 210.00

5 HP GAS

CODE 0214	
DAY	\$ 40.00
WEEK	\$ 140.00
MONTH	\$ 400.00

1 1/2 HP HAND CARRY AIR COMPRESSOR



115V AC

CODE 0202	
DAY	\$ 30.00
WEEK	\$ 96.00
MONTH	\$ 180.00

FRAMING NAILER



WE STOCK NAILS

CODE 0409	
DAY	\$ 20.00
WEEK	\$ 64.00
MONTH	\$ 120.00

AIR IMPACT WRENCH



1" DRIVE

CODE 0456	
DAY	\$ 25.00
WEEK	\$ 80.00
MONTH	\$ 150.00

3/4" DRIVE

CODE 0515	
DAY	\$ 20.00
WEEK	\$ 64.00
MONTH	\$ 120.00

1/2" DRIVE

CODE 0510	
DAY	\$ 10.00
WEEK	\$ 32.00
MONTH	\$ 100.00

AIR FINISH NAILER

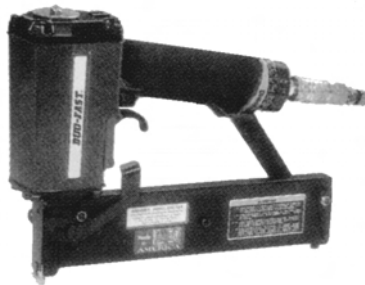

CODE 0406	
DAY	\$ 15.00
WEEK	\$ 48.00
MONTH	\$ 90.00



AIR MASONITE STAPLER FOR UNDERLAYMENT



CODE 0401	
DAY	\$ 15.00
WEEK	\$ 48.00
MONTH	\$ 90.00

ROOFING STAPLERS



WE STOCK STAPLES

CODE 0407	
DAY	\$ 15.00
WEEK	\$ 48.00
MONTH	\$ 90.00

ROOFING COIL NAILER



CODE 0402	
DAY	\$ 25.00
WEEK	\$ 80.00
MONTH	\$ 150.00

FRAMING STAPLERS



CODE 0408	
DAY	\$ 15.00
WEEK	\$ 48.00
MONTH	\$ 90.00



JACKS AND HOISTS

PORTA POWER

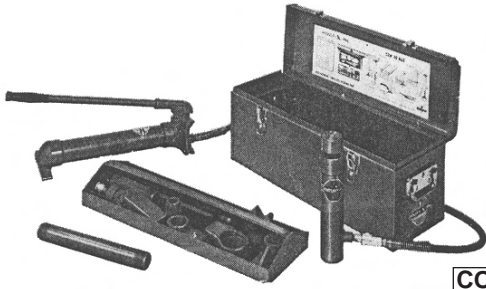

**(FOR BODY WORK ONLY)
4 TON CAPACITY**

CODE 1375	
DAY	\$ 25.00
WEEK	\$ 80.00
MONTH	\$ 150.00

SCREW JACKS



CODE 4910	
DAY	\$ 7.50
WEEK	\$ 24.00
MONTH	\$ 45.00

2 TON GARAGE SERVICE JACKS



CODE 1340	
DAY	\$ 15.00
WEEK	\$ 48.00
MONTH	\$ 90.00

HOISTS 1 TON COME-A-LONGS



CODE 3916	
DAY	\$ 7.50
WEEK	\$ 24.00
MONTH	\$ 45.00

HYDRAULIC JACKS



12 TON

20 TON

CODE 4940	
DAY	\$ 7.50
WEEK	\$ 24.00
MONTH	\$ 45.00

CODE 4945	
DAY	\$ 10.00
WEEK	\$ 32.00
MONTH	\$ 60.00

ENGINE STAND

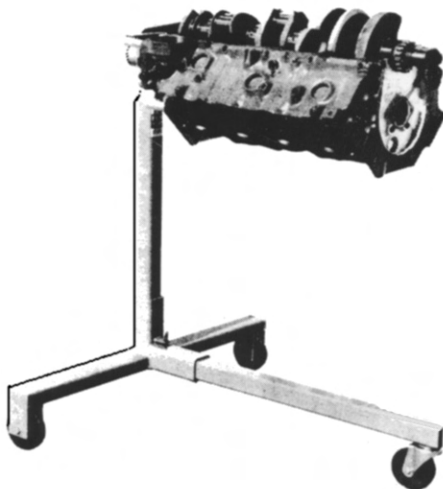

CODE 1236	
DAY	\$ 7.50
WEEK	\$ 24.00
MONTH	\$ 45.00

TRANSMISSION JACK

**LIFT HEIGHT 30"
CAPACITY 1764 LBS.**



CODE 1326	
DAY	\$ 20.00
WEEK	\$ 64.00
MONTH	\$ 120.00



TORQUE WRENCH



FT/LBS 0-250 0-600

	CODE 1312	1314
DAY	\$ 10.00	\$ 25.00
WEEK	\$ 32.00	\$ 80.00
MONTH	\$ 60.00	\$ 150.00

VACUUM PUMP 115V AC FOR SMALL SYSTEMS

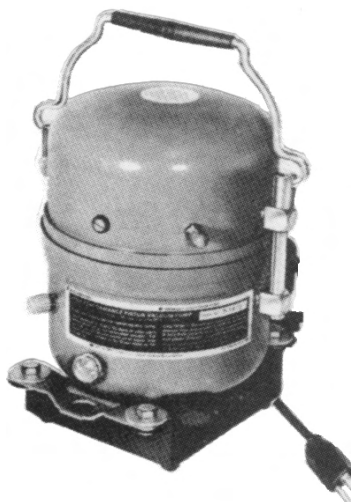

	CODE 3265
DAY	\$ 15.00
WEEK	\$ 48.00
MONTH	\$ 90.00

COIL SPRING COMPRESSOR

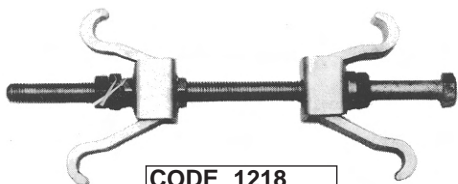

	CODE 1218
DAY	\$ 10.00
WEEK	\$ 32.00
MONTH	\$ 60.00

MANIFOLD A/C GAUGES

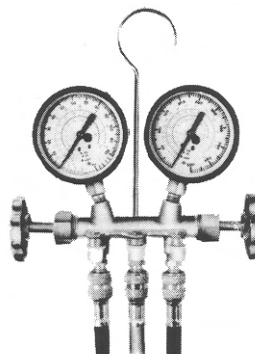

FOR R12
OR R22
USE ONLY

	CODE 3266
DAY	\$ 15.00
WEEK	\$ 48.00
MONTH	\$ 90.00

SLIDE ARM HAMMER



	CODE 1254
DAY	\$ 10.00
WEEK	\$ 32.00
MONTH	\$ 60.00

PORTABLE AIR TANK



	CODE 0538
DAY	\$ 5.00
WEEK	\$ 32.00
MONTH	\$ 60.00

DENT PULLER



	CODE 1249
DAY	\$ 10.00
WEEK	\$ 32.00
MONTH	\$ 60.00

McPHERSON STRUT COMPRESSOR

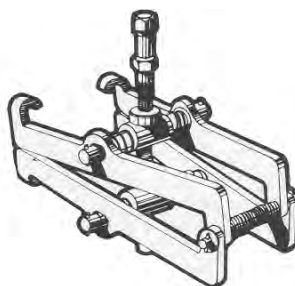

	CODE 1219
DAY	\$ 10.00
WEEK	\$ 32.00
MONTH	\$ 60.00



MECHANICS TOOLS

ELECTRIC IMPACT WRENCHES

**BOLT CAPACITY : 5/8"
MAX. TORQUE : 185FT/LBS**

**BOLT CAPACITY: 7/8"
MAX. TORQUE: 220 FT/LBS**

1/2" SQUARE DRIVE

CODE 8318	
DAY	\$ 15.00
WEEK	\$ 48.00
MONTH	\$ 90.00

3/4" SQUARE DRIVE

CODE 8319	
DAY	\$ 20.00
WEEK	\$ 64.00
MONTH	\$ 120.00



1" SQUARE DRIVE

CODE 8320	
DAY	\$ 25.00
WEEK	\$ 80.00
MONTH	\$ 150.00

**BOLT CAPACITY: 1 1/4"
MAX. TORQUE : 590 FT / LBS.**



3 ARM PULLER

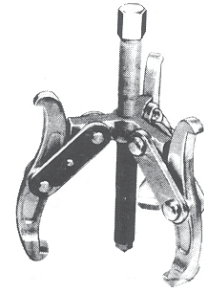

CODE 1253	
DAY	\$ 10.00
WEEK	\$ 32.00
MONTH	\$ 60.00

INSIDE BEARING PULLER



CODE 1205	
DAY	\$ 10.00
WEEK	\$ 32.00
MONTH	\$ 60.00

IF YOU DON'T SEE WHAT YOU NEED HERE, PLEASE CALL, WE MAY HAVE WHAT YOU NEED!

PITMAN ARM PULLER



CODE 1253	
DAY	\$ 10.00
WEEK	\$ 32.00
MONTH	\$ 60.00

BRAKE DRUM PULLER



CODE 1255	
DAY	\$ 10.00
WEEK	\$ 32.00
MONTH	\$ 60.00

CYLINDER HONE



CODE 1246	
DAY	\$ 10.00
WEEK	\$ 32.00
MONTH	\$ 60.00

HARMONIC BALANCER PULLER



CODE 1239	
DAY	\$ 10.00
WEEK	\$ 32.00
MONTH	\$ 60.00

2 ARM PULLERS

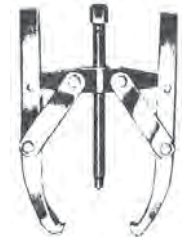

CODE 1253	
DAY	\$ 10.00
WEEK	\$ 32.00
MONTH	\$ 60.00

AUTOMOTIVE EQUIPMENT



RENT-A-KADDY CAR DOLLY

TOWED VEHICLE TREAD WIDTH
MINIMUM 42" MAXIMUM 76"



Specifications:
Overall Width 95"
Overall Length . . . 123"
Weight 480 lbs
Axle Capacity 3,500 lbs
Max. Loaded
Weight 2,540 lbs

**PERMANENT HITCH
WITH 2" BALL REQUIRED**

(LOCAL RENTALS ONLY)

CODE 1322	
4 HRS	\$ 35.00
DAY	\$ 50.00
WEEK	\$ 175.00
MONTH	\$ 500.00

ENGINE SLING



CODE 3935	
DAY	\$ 2.50
WEEK	\$ 8.00
MONTH	\$ 15.00

PORTA CRANE

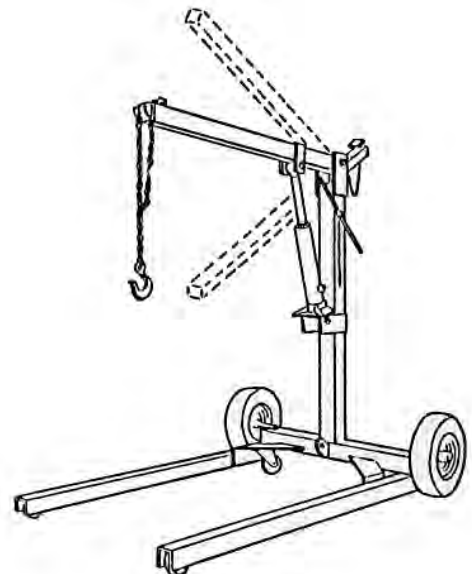

CODE 3934	
4 HRS	\$ 15.00
DAY	\$ 25.00
WEEK	\$ 80.00
MONTH	\$ 150.00



FLOOR INSTALLATION AND CARE

DOOR JAMB SAW



CODE 7426	
4 HRS	\$ 20.00
DAY	\$ 35.00
WEEK	\$ 112.00
MONTH	\$ 210.00

BLADE INCLUDED

HARDWOOD FLOOR NAILERS

ANGLE NAILER

CODE 3212	
DAY	\$ 20.00
WEEK	\$ 64.00
MONTH	\$ 120.00

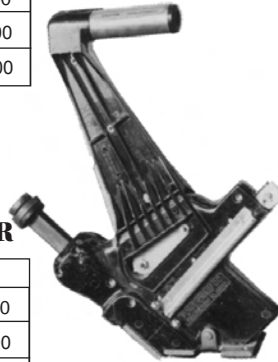

FACE NAILER

CODE 3213	
DAY	\$ 10.00
WEEK	\$ 32.00
MONTH	\$ 60.00

AIR POWERED ANGLE NAILER



CODE 0403	
DAY	\$ 30.00
WEEK	\$ 96.00
MONTH	\$ 180.00

AIR POWERED HARDWOOD FLOOR STAPLER



Thin Flooring

CODE 0411	
DAY	\$ 30.00
WEEK	\$ 96.00
MONTH	\$ 180.00

Regular Flooring

CODE 3211	
DAY	\$ 30.00
WEEK	\$ 96.00
MONTH	\$ 180.00

STUD GUNS LOW VELOCITY WE CARRY A FULL LINE OF STUD GUN SUPPLIES



CODE 8536	
4 HRS	\$ 15.00
DAY	\$ 25.00
WEEK	\$ 80.00
MONTH	\$ 150.00

AIR MASONITE GUN AVAILABLE SEE PAGE 55

MASONITE STAPLER

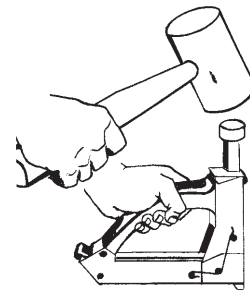

CODE 3214	
DAY	\$ 15.00
WEEK	\$ 48.00
MONTH	\$ 90.00

FLOOR SANDER



**ASK ABOUT
OUR HOW TO
TAPE ON
HARDWOOD
FLOOR
REFINISHING**

CODE 3208	
4 HRS	\$ 20.00
DAY	\$ 35.00
WEEK	\$ 112.00
MONTH	\$ 210.00

FLOOR EDGER



CODE 3209	
4 HRS	\$ 15.00
DAY	\$ 25.00
WEEK	\$ 80.00
MONTH	\$ 150.00

FLOOR SANDER



4 DISC U SAND

CODE 3207	
4 HRS	\$ 20.00
DAY	\$ 35.00
WEEK	\$ 112.00
MONTH	\$ 210.00

FLOOR AND CARPET CARE



TURBO DRYER FOR DRYING WET CARPETS



CODE 3860	
DAY	\$ 25.00
WEEK	\$ 80.00
MONTH	\$ 150.00

CARPET CLEANER W/AGITATOR BRUSHES ONE PASS CARPET CLEANING POWER IN A COMPACT SELF CONTAINED EXTRACTOR



CODE 3250	
4 HRS	\$ 25.00
DAY	\$ 40.00
WEEK	\$ 125.00
MONTH	\$ 240.00

WET OR DRY VACUUM



CODE 3262	
4 HRS	\$ 12.00
DAY	\$ 20.00
WEEK	\$ 64.00
MONTH	\$ 120.00

FLOOR POLISHERS & RUG SCRUBBERS



12"

CODE 3230	
4 HRS	\$ 9.00
DAY	\$ 15.00
WEEK	\$ 48.00
MONTH	\$ 90.00

16"

CODE 3235	
4 HRS	\$ 12.00
DAY	\$ 20.00
WEEK	\$ 64.00
MONTH	\$ 120.00

HI-SPEED BUFFER

CODE 3232	
DAY	\$ 25.00
WEEK	\$ 80.00
MONTH	\$ 175.00

FULL LINE OF FLOOR CARE
PRODUCTS AVAILABLE

UPRIGHT VACUUM



CODE 3264	
DAY	\$ 20.00
WEEK	\$ 64.00
MONTH	\$ 120.00

CLEANER STEAMER



CODE 3239	
4 HRS	\$ 12.00
DAY	\$ 30.00
WEEK	\$ 96.00
MONTH	\$ 300.00

COMMERCIAL UNIT

CODE 3242	
4 HRS	\$ 20.00
DAY	\$ 35.00
WEEK	\$ 112.00
MONTH	\$ 210.00

STAIR & UPHOLSTERY TOOL

CODE 3241	
DAY	\$ 5.00
WEEK	\$ 16.00
MONTH	\$ 30.00



CARPET & TILE TOOLS

TILE SAW



BLADE INCLUDED

12"

CODE 7409	
4 HRS	\$ 35.00
DAY	\$ 55.00
WEEK	\$ 176.00
MONTH	\$ 330.00

18"

CODE 7407	
4 HRS	\$ 50.00
DAY	\$ 75.00
WEEK	\$ 240.00
MONTH	\$ 450.00

FLOOR STRIPPER

**GREAT FOR REMOVING
TILE AND CARPET**



BLADES EXTRA

CARPET SEAM ROLLER



CODE 3226	
DAY	\$ 5.00
WEEK	\$ 17.50
MONTH	\$ 50.00

CODE 3229	
4 HRS	\$ 25.00
DAY	\$ 45.00
WEEK	\$ 144.00
MONTH	\$ 270.00

HEAT BOND SEAMING KIT

**SEAM TAPE
AVAILABLE**



CODE 3220	
DAY	\$ 7.50
WEEK	\$ 24.00
MONTH	\$ 48.00

POWER STRETCHER



CODE 3238	
DAY	\$ 20.00
WEEK	\$ 64.00
MONTH	\$ 120.00

CERAMIC TILE CUTTER



NIBBLERS AVAILABLE

CODE 2618	
DAY	\$ 10.00
WEEK	\$ 32.00
MONTH	\$ 60.00

KNEE KICKER



CODE 3225	
DAY	\$ 7.50
WEEK	\$ 24.00
MONTH	\$ 45.00

LINOLEUM ROLLER



CODE 3228	
DAY	\$ 10.00
WEEK	\$ 32.00
MONTH	\$ 60.00

CARPET STAPLER

**9/16 FINE-WIRE, NARROW
CROWN STAPLES
-IDEAL FOR INSTALLING CARPET
AND FASTENING UPHOLSTERY**



CODE 8545	
DAY	\$ 15.00
WEEK	\$ 48.00
MONTH	\$ 90.00

VINYL TILE CUTTER



CODE 2619	
DAY	\$ 15.00
WEEK	\$ 48.00
MONTH	\$ 90.00

LAWN & GARDEN



GAS CHAIN SAWS

ELECTRIC CHAIN SAW



CODE 7480	
4 HRS	\$ 20.00
DAY	\$ 35.00
WEEK	\$ 122.50
MONTH	\$ 210.00

16"- 20" BAR

CODE 7481	
4 HRS	\$ 30.00
DAY	\$ 45.00
WEEK	\$ 157.50
MONTH	\$ 270.00



24"/28" BAR

CODE 7482	
4 HRS	\$ 50.00
DAY	\$ 70.00
WEEK	\$ 245.00
MONTH	\$ 420.00

LOGSPLITTERS

CODE 5044	
4 HRS	\$ 45.00
DAY	\$ 60.00
WEEK	\$ 210.00
MONTH	\$ 600.00



POLE PRUNER SAW

EXTENDS TO 11' 2"



GAS

CODE 5009	
4 HRS	\$ 40.00
DAY	\$ 60.00
WEEK	\$ 210.00
MONTH	\$ 600.00

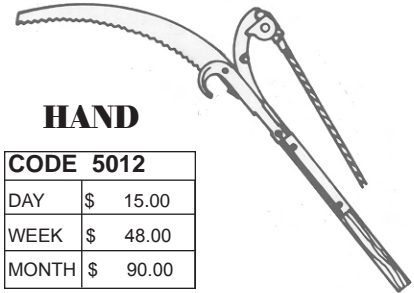

HAND

CODE 5012	
DAY	\$ 15.00
WEEK	\$ 48.00
MONTH	\$ 90.00

ANGLE HEDGE TRIMMER



CODE 5038	
4 HRS	\$ 20.00
DAY	\$ 35.00
WEEK	\$ 122.50
MONTH	\$ 350.00



STRING & BLADE TYPE WEED CUTTER



CODE 5030	
4 HRS	\$ 20.00
DAY	\$ 30.00
WEEK	\$ 105.00
MONTH	\$ 180.00

HEDGE TRIMMERS



GAS

CODE 5035	
4 HRS	\$ 14.00
DAY	\$ 25.00
WEEK	\$ 87.50
MONTH	\$ 250.00

ELECTRIC

CODE 5034	
4 HRS	\$ 6.00
DAY	\$ 10.00
WEEK	\$ 32.00
MONTH	\$ 60.00

" BILLY GOAT VACUUM"

SEVERAL APPLICATIONS
LAWNS, PARKING LOTS
CONSTRUCTION SITES



COMMERCIAL
UNIT

CODE 5144	
4 HRS	\$ 40.00
DAY	\$ 55.00
WEEK	\$ 192.00
MONTH	\$ 550.00



LAWN & GARDEN

18" SOD CUTTER



CODE 5118	
4 HRS	\$ 60.00
DAY	\$ 80.00
WEEK	\$ 280.00
MONTH	\$ 800.00

POWER RAKE (DETHATCHER)



REMOVES DEAD
GRASS

CODE 5066	
4 HRS	\$ 35.00
DAY	\$ 50.00
WEEK	\$ 175.00
MONTH	\$ 500.00

COMMERCIAL TYPE CORE AERATOR



18" PASS

CODE 5003	
4 HRS	\$ 45.00
DAY	\$ 65.00
WEEK	\$ 227.50
MONTH	\$ 650.00

25" PASS

CODE 5002	
4 HRS	\$ 60.00
DAY	\$ 80.00
WEEK	\$ 280.00
MONTH	\$ 800.00

VERTICUTTER W/OVERSEEDER



CODE 5064	
4 HRS	\$ 60.00
DAY	\$ 75.00
WEEK	\$ 262.50
MONTH	\$ 750.00

"COMMERCIAL" SELF PROPELLED POWER SEEDER



36" TOWABLE CORE AERATOR



CODE 5004	
4 HRS	\$ 35.00
DAY	\$ 50.00
WEEK	\$ 160.00
MONTH	\$ 300.00

OVERSEEDS UP TO 15,000 SQ. FT PER
HOUR

VERTICUTS AND SEEDS IN ONE
PASS.

CODE 5075	
4 HRS	\$ 75.00
DAY	\$ 100.00
WEEK	\$ 350.00
MONTH	\$ 1000.00

LAWN & GARDEN



4' LANDSCAPE RAKE

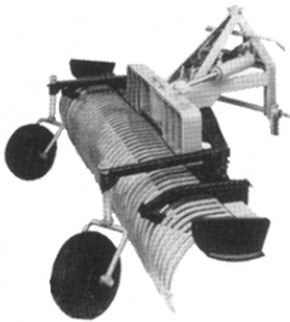

CODE 5048	
DAY	\$ 20.00
WEEK	\$ 64.00
MONTH	\$ 120.00

LAWN ROLLERS

PUSH

CODE 5068	
DAY	\$ 7.50
WEEK	\$ 24.00
MONTH	\$ 45.00

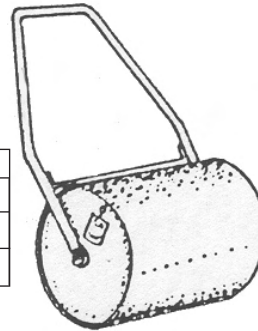

TOWABLE

CODE 5069	
DAY	\$ 15.00
WEEK	\$ 45.00
MONTH	\$ 90.00

FERTILIZER SPREADER

PUSH

CODE 5134	
DAY	\$ 5.00
WEEK	\$ 16.00
MONTH	\$ 30.00



TOWABLE

CODE 5049	
DAY	\$ 20.00
WEEK	\$ 64.00
MONTH	\$ 120.00

CYCLONE SPREADER

PUSH

CODE 5133	
DAY	\$ 20.00
WEEK	\$ 64.00
MONTH	\$ 120.00



TOWABLE

CODE 5054	
DAY	\$ 20.00
WEEK	\$ 64.00
MONTH	\$ 120.00

BED EDGER

**PERFECT FOR EDGING
FLOWER BEDS**

PERFECT FOR
"INVISIBLE
FENCE"
INSTALLATION



CODE 5026	
4 HRS	\$ 45.00
DAY	\$ 65.00
WEEK	\$ 227.50
MONTH	\$ 650.00

EDGER TRIMMER



CODE 5153	
4 HRS	\$ 25.00
DAY	\$ 35.00
WEEK	\$ 122.50
MONTH	\$ 350.00

MINI TILLER CULTIVATOR



CODE 5140	
4 HRS	\$ 20.00
DAY	\$ 30.00
WEEK	\$ 105.00
MONTH	\$ 300.00

ROTO-TILLER

CODE 5143	
4 HRS	\$ 30.00
DAY	\$ 45.00
WEEK	\$ 157.50
MONTH	\$ 450.00





HYDRAULIC TILLER

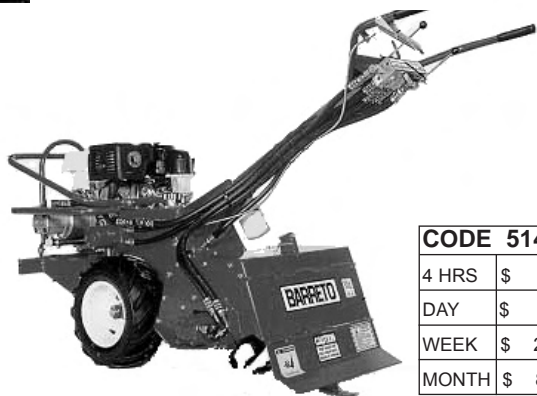

CODE 5147	
4 HRS	\$ 60.00
DAY	\$ 80.00
WEEK	\$ 280.00
MONTH	\$ 800.00

LAWN & GARDEN

WE SELL ARBORISTS PRODUCTS

- ROPES •
- SADDLES •
- SPIKES •



BACK PACK BLOWER



CODE 5006	
4 HRS	\$ 30.00
DAY	\$ 45.00
WEEK	\$ 157.50
MONTH	\$ 450.00

LEAF BLOWER



CODE 5005	
4 HRS	\$ 25.00
DAY	\$ 40.00
WEEK	\$ 140.00
MONTH	\$ 400.00

MOWERS



SELF-PROPELLED

CODE 5057	
4 HRS	\$ 18.00
DAY	\$ 25.00
WEEK	\$ 87.50
MONTH	\$ 250.00

COMMERCIAL GRASS MOWER



COMMERCIAL WEEDCUTTER

CODE 5008	
DAY	\$ 70.00
WEEK	\$ 245.00
MONTH	\$ 700.00



SELF PROPELLED

36"

CODE 5015	
DAY	\$ 65.00
WEEK	\$ 227.50
MONTH	\$ 650.00

48"

CODE 5016	
DAY	\$ 75.00
WEEK	\$ 262.50
MONTH	\$ 750.00

COMMERCIAL GROUND CARE



LARGE BRUSH CHIPPERS

6" CAPACITY

CODE 5055	
4 HRS	\$ 175.00
DAY	\$ 225.00
WEEK	\$ 787.50
MONTH	\$ 2250.00

HYDRAULIC FEED

12" CAPACITY

CODE 5058	
4 HRS	\$ 200.00
DAY	\$ 350.00
WEEK	\$ 1225.00
MONTH	\$ 3500.00



STUMP AND ROOT GRINDER



WEIGHT 420 LBS
LENGTH 66"
WIDTH 29.5"
STUMP SIZE UNLIMITED
ENGINE 20 HP

CODE 5080	
4 HRS	\$ 100.00
DAY	\$ 150.00
WEEK	\$ 525.00
MONTH	\$ 1500.00

LARGE STUMP GRINDER

UNIT COMES WITH ITS OWN
EASY LOAD TRAILER

SELF-PROPELLED

HYDRAULIC, SWING
RAISE AND LOWER



49.5" WIDE

CODE 5082	
4 HRS	\$ 175.00
DAY	\$ 250.00
WEEK	\$ 875.00
MONTH	\$ 2500.00

FOR ALL YOUR HYDROSEEDER SUPPLIES

CALL

LESCO

8415 PROGRESS DR. SUITE H,J
 FREDERICK, MD 21701
 PH. 301-695-0232

221 MCRAND COUET SUITE 100
 HAGERSTOWN, MD 21740
 PH. 240-420-3972

7620-A RICKENBACKER DR.
 GAITHERSBURG, MD 20879
 PH. 301-840-5774

14000 WILLARD RD.
 CHANTILLY, VA. 20151
 PH. 703-631-3224

HYDROSEEDER



500 GALLON CAPACITY

HOLDS 200-250LBS MULCH

CODE 5101	
DAY	\$ 200.00
WEEK	\$ 700.00
MONTH	\$ 2000.00



COMMERCIAL GROUND CARE

PORTABLE WATER TANKS

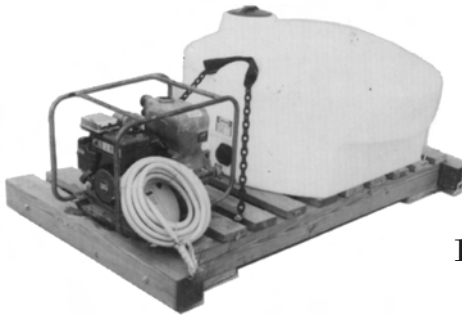

**GAS POWERED PUMP
WATER ONLY**

200 GALLON

CODE 7820	
DAY	\$ 55.00
WEEK	\$ 192.50
MONTH	\$ 550.00

1000 GALLON

CODE 7830	
DAY	\$ 100.00
WEEK	\$ 350.00
MONTH	\$ 1000.00

POST DRIVER



CODE 1045	
DAY	\$ 5.00
WEEK	\$ 16.00
MONTH	\$ 30.00

POST HOLE DIGGER

ONE MAN OPERATION



6" OR 8" AUGER

CODE 1024	
4 HRS	\$ 25.00
DAY	\$ 40.00
WEEK	\$ 140.00
MONTH	\$ 400.00

POST HOLE DIGGER

6", 8", 10" & 12"
AUGERS
AVAILABLE



2 MAN
GASOLINE
OPERATED

CODE 1050	
4 HRS	\$ 35.00
DAY	\$ 50.00
WEEK	\$ 175.00
MONTH	\$ 500.00



WE CARRY A FULL LINE
OF SAKRETE PRODUCTS
TO COMPLETE YOUR JOB !

ONE MAN POST HOLE DIGGER

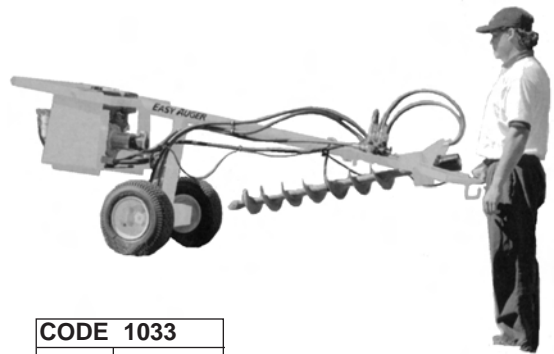

CODE 1033	
4 HRS	\$ 45.00
DAY	\$ 65.00
WEEK	\$ 227.50
MONTH	\$ 650.00

6", 8", 10", 12", 14", OR 16"
AUGERS
AVAILABLE

STRAW BLOWER



CODE 3811	
4 HRS	\$ 60.00
DAY	\$ 85.00
WEEK	\$ 297.50
MONTH	\$ 850.00

LARGE STRAW BLOWER

BLOWS STRAW 60 FEET
7 TONS PER HOUR CAPACITY

TRAILER INCLUDED



CODE 3835	
DAY	\$ 200.00
WEEK	\$ 700.00
MONTH	\$ 2000.00

MATERIAL HANDLING



PALLET TRUCK

**4500 LB.
CAPACITY**

28" WIDTH



**NARROW UNITS
AVAILABLE**

CODE 5770	
DAY	\$ 25.00
WEEK	\$ 80.00
MONTH	\$ 150.00

MANUALLY OPERATED LIFTS



**GENIE LIFT
TELESCOPIC**

LIFTS TO 18'

CODE 5735	
DAY	\$ 40.00
WEEK	\$ 140.00
MONTH	\$ 450.00



ROLL -A- LIFTS



4000 lb.

CODE 5744	
DAY	\$ 35.00
WEEK	\$ 112.00
MONTH	\$ 210.00

6000 LB.

CODE 5745	
DAY	\$ 40.00
WEEK	\$ 128.00
MONTH	\$ 240.00

**PRICE IS FOR A PAIR, ROLL-A-LIFTS
ARE USED IN PAIRS**

CHAIN FALLS

2 TON

CODE 3950	
DAY	\$ 20.00
WEEK	\$ 60.00
MONTH	\$ 120.00

3 TON

CODE 3951	
DAY	\$ 25.00
WEEK	\$ 75.00
MONTH	\$ 150.00





MATERIAL HANDLING

JOHNSON BAR

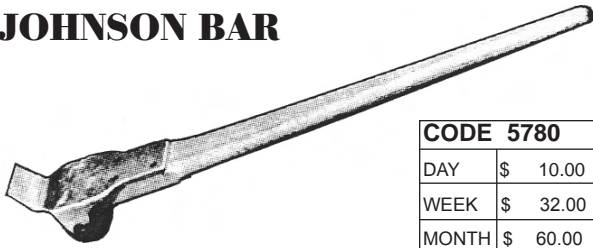

CODE 5780	
DAY	\$ 10.00
WEEK	\$ 32.00
MONTH	\$ 60.00

4 WHEEL DOLLY 18" X 30"



CODE 5710	
DAY	\$ 7.50
WEEK	\$ 24.00
MONTH	\$ 45.00

HEAVY EQUIPMENT DOLLY



CODE 5750	
DAY	\$ 25.00
WEEK	\$ 80.00
MONTH	\$ 150.00

**6000 LB.
CAPACITY**

BANDING TOOL

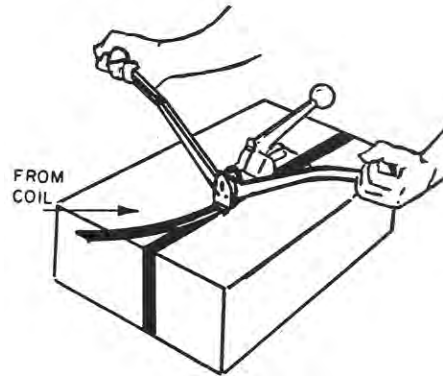

**STEEL BANDING
AVAILABLE**

CODE 5760	
DAY	\$ 15.00
WEEK	\$ 48.00
MONTH	\$ 90.00

HEAVY DUTY APPLIANCE TRUCK



CODE 5705	
DAY	\$ 10.00
WEEK	\$ 32.00
MONTH	\$ 60.00

GLASS SUCTION CUPS



CODE 5790	
DAY	\$ 5.00
WEEK	\$ 16.00
MONTH	\$ 30.00

WAREHOUSE TYPE

CODE 5706	
DAY	\$ 10.00
WEEK	\$ 32.00
MONTH	\$ 60.00



MOVING PADS

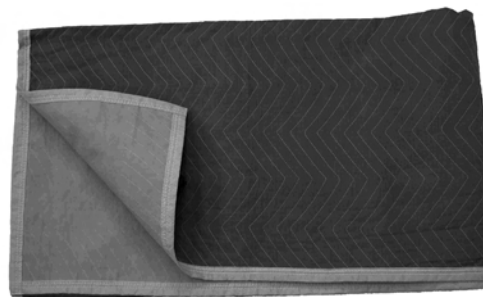

PER DOZEN	
CODE 5715	
DAY	\$ 10.00
WEEK	\$ 32.00
MONTH	\$ 60.00

LADDERS



ALUMINUM STEP LADDERS 6' TO 16'



CODE 6206 6'	
6208 8'	
6210 10'	
DAY	\$ 10.00
WEEK	\$ 32.00
MONTH	\$ 60.00

CODE 6212 12'	
DAY	\$ 15.00
WEEK	\$ 48.00
MONTH	\$ 90.00

CODE 6216 16'	
DAY	\$ 25.00
WEEK	\$ 80.00
MONTH	\$ 150.00

DRYWALL LIFT UP TO 10' HEIGHT



CODE 5755	
DAY	\$ 20.00
WEEK	\$ 64.00
MONTH	\$ 120.00

ASK ABOUT OUR DRYWALL
HOW TO TAPE

ALUMINUM EXTENSION LADDERS

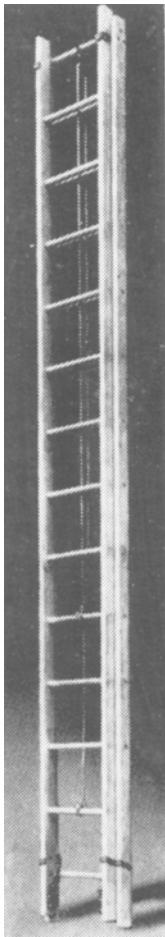

24'

CODE 6224	
DAY	\$ 20.00
WEEK	\$ 64.00
MONTH	\$ 120.00

32'

CODE 6232	
DAY	\$ 25.00
WEEK	\$ 80.00
MONTH	\$ 150.00

40'

CODE 6240	
DAY	\$ 30.00
WEEK	\$ 96.00
MONTH	\$ 180.00

DRYWALL CART



CODE 5756	
DAY	\$ 20.00
WEEK	\$ 64.00
MONTH	\$ 120.00



ALUMINUM BENDING TOOL

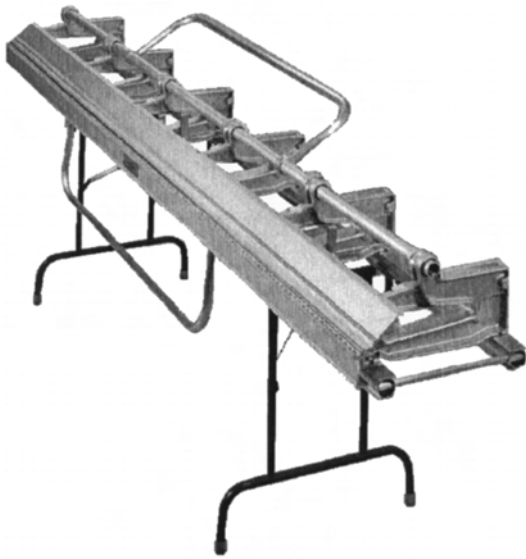

8' MODEL

CODE 2610	
DAY	\$ 30.00
WEEK	\$ 96.00
MONTH	\$ 180.00

10' MODEL

CODE 2603	
DAY	\$ 40.00
WEEK	\$ 128.00
MONTH	\$ 240.00

ALUMINUM ARCHED RAMP

**89" LONG- 12" WIDE
LOAD CAPACITY 1600 LBS.
WEIGHT 40 LBS.**

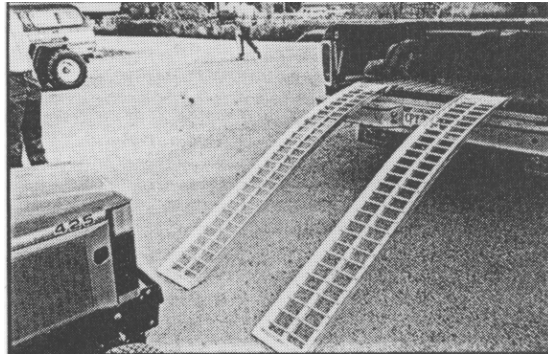

CODE 5667	
DAY	\$ 7.50
WEEK	\$ 24.00
MONTH	\$ 45.00

METAL DETECTORS

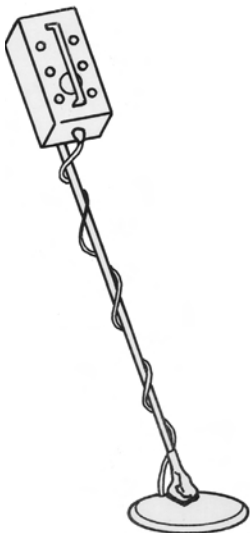

CODE 8390	
4 HRS	\$ 12.00
DAY	\$ 20.00
WEEK	\$ 64.00
MONTH	\$ 120.00

DRIGGING & RIGGING INC.

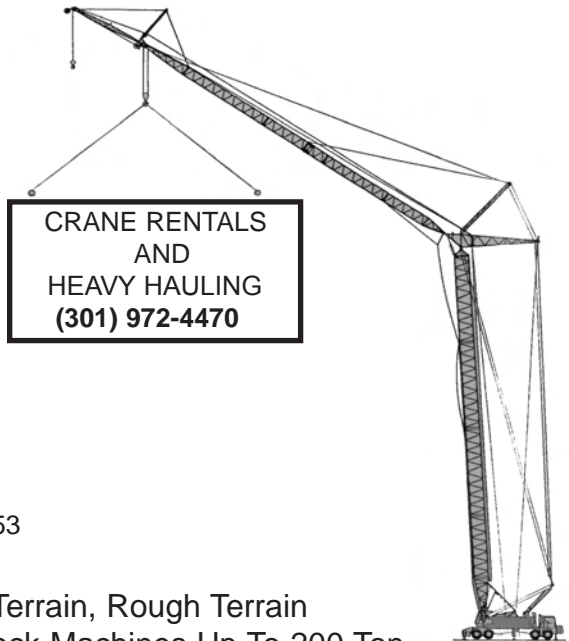

CRANE RENTALS
AND
HEAVY HAULING
(301) 972-4470

24-Hr. Emergency#
(301) 831-7262
Fax Number (301) 972-5153

Truck, All-Terrain, Rough Terrain
& Carry Deck Machines Up To 200 Ton
Capacity With 370' Boom
Serving The Mid-Atlantic Region

23924 Frederick Road Clarksburg, MD 20871
6037 Buffalo Road Mt. Airy, MD 21771



CREDIT APPLICATION

ACCT #	<input type="text"/>
LIMIT	<input type="text"/>
APPROVED BY	<input type="text"/>
SIC CODE #	<input type="text"/>
SALES REP	<input type="text"/>

ACCOUNT NAME _____

ADDRESS _____

CITY _____ STATE _____ ZIP _____

PHONE _____ FAX _____ CELL PHONE _____

TYPE OF BUSINESS _____ YEAR ESTABLISHED _____ #OF EMPLOYEES _____

OWNERSHIP: CORPORATION _____ PARTNERSHIP _____ SOLE PROPRIETORSHIP _____ OTHER _____

FEDERAL ID NUMBER _____ SOCIAL SECURITY # _____

PRINCIPLE OWNER(S) _____

PURCHASING AGENT OR EQUIPMENT MANAGER _____ ACCOUNTS PAYABLE MANAGER _____

BUSINESS ACCOUNT - NAME OF BANK _____ ACCT. # _____

BRANCH ADDRESS _____ PHONE _____

CREDIT REFERENCES:

1. Name _____

Address/Phone/Fax _____

2. Name _____

Address/Phone/Fax _____

PURCHASE ORDERS REQUIRED? _____ YES _____ NO JOB NAME REQUIRED? _____ YES _____ NO

TERMS: NET 30 DAYS ON APPROVED ACCOUNTS. SERVICE CHARGE OF 1 1/2% PER MONTH ADDED TO ANY AMOUNT NOT PAID WITHIN 30 DAYS.

I/WE MAKE APPLICATION FOR CREDIT WITH YOUR FIRM AND ACCEPT THE TERMS AS INDICATED ABOVE.

I ACCEPT THE TERMS OF THE DAMAGE WAIVER DISCLOSED ON THE BACK OF THIS CREDIT APPLICATION _____ YES _____ NO

HOW DID YOU FIND OUT ABOUT US?

The One Book Yellow Pages
 Salesman Newspaper
 Trade Show Other

DESIRED CREDIT LIMIT _____

SIGNED _____ DATE _____

Mail completed application to:
RENTALS UNLIMITED, INC.
P.O. BOX 600
CLARKSBURG, MARYLAND 20871

OR: FAX: (301) 972-2557
ATTN: CREDIT DEPARTMENT

DAMAGE WAIVER



DEFINITION:

WHEREVER THE TERM EQUIPMENT IS USED IT SHALL MEAN TRUCKS, MOBILE EQUIPMENT, STATIONARY EQUIPMENT, HAND TOOLS, ETC. OR ANY OTHER ITEMS FOR RENT.

LOSS OR DAMAGE TO EQUIPMENT-

CUSTOMER IS LIABLE FOR ALL DAMAGE, LOSS OR THEFT OF TRUCKS AND EQUIPMENT.

DAMAGE WAIVER:

WITH THE EXCEPTION OF TRUCK OVERHEAD DAMAGE, CUSTOMER ACCEPTANCE OF DAMAGE WAIVER RELIEVES CUSTOMER FROM LIABILITY FOR DAMAGE TO THE EQUIPMENT PROVIDED THE FOLLOWING PROHIBITED USES ARE MET:

- a. USED FOR ANY ILLEGAL PURPOSE OR MANNER;
 - b. USED WHEN IN NEED OF LUBRICATION OR REPAIR OR WHEN UNSAFE;
 - c. USED IN ANY RACE, TEST OR CONTEST,
 - d. USED BEYOND ITS RATED CAPACITY,
 - e. USED WITHOUT THE SAFEGUARDS PROVIDED;
 - f. LOANED, ASSIGNED OR SUBLETTED;
 - g . USED OUT-OF-STATE WITHOUT WRITTEN CONSENT,
 - h. OPERATED BY MINOR OR DRIVEN BY,UNLICENSED PERSON;
 - i. (TRAILER): IF USED WITH OTHER THAN SPECIFIED VEHICLE;
 - j . OPERATED WHILE INTOXICATED OR IMPAIRED;
 - k. LEFT RUNNING UNATTENDED;
 - l. USED ANYWHERE THAN SPECIFIED SITE;
 - m. ANY OTHER UNREASONABLE OR INTENTIONAL ABUSE OR MISUSE;
 - n. KEY LEFT IN EQUIPMENT OR VEHICLE.
- THEFT IS NOT A LOSS AND IS NOT COVERED UNDER DAMAGE WAIVER.

COST:

DAMAGE WAIVER IS 12% OF THE TOTAL RENTAL.
VEHICLES, \$14.00 PER DAY, \$98.00 PER WEEK, \$392.00 PER MONTH



APLICACION PARA CREDITO

CUENTA #	<input type="text"/>	<input type="text"/>	<input type="text"/>	<input type="text"/>	<input type="text"/>	<input type="text"/>
LIMITE	_____					
APROBADO POR	_____					
CODIGO SIC#	_____					
REP. DE VENTAS	_____					

NOMBRE _____

DIRECCION _____

CIUDAD _____ ESTADO _____ CODIGO DE AREA _____

TELEFONO _____ FAX _____ TELEFONO CELULAR _____

TIPO DE NEGOCIO _____ AÑOS DE ESTABLECIDO _____ # DE EMPLEADOS _____

PROPIEDAD: _____ CORPORACION _____ SOCIO _____ UNICO PROPIETARIO _____ OTRO

NUMERO DE IDENTIFICATION FEDERAL _____ # DE SEGURO SOCIAL _____

PROPIETARIO(S) PRINCIPAL(ES) _____

GERENTE DE COMPRAS _____ GERENTE DE PAGOS _____

CUENTAS COMERCIALES

NOMBRE DEL BANCO _____ CUENTA# _____

DIRECCION SUCURSAL _____ TELEFONO _____

REFERENCIAS DE CREDITO:

1. Nombre _____

Direccion/Tèlefono/Fax _____

2. Nombre _____

Direccion/Tèlefono/Fax _____

ORDENES DE COMPRA REQUERIDA? _____ SI _____ NO NOMBRE DEL TRABAJO REQUERIDO? _____ SI _____ NO

CONDICIONES DE PAGO: NETO A 30 DIAS EN CUENTAS APROBADAS; SE CARGARA 1.1/2 % POR MES EN CADA CUENTA SIN CANCELAR DURANTE LOS PRIMEROS 30 DIAS.

YO/NOSOTROS HACEMOS APLICACION PARA CREDITO CON SU FIRMA Y ACEPTAMOS LOS TERMINOS INDICADOS ARRIBA.

YO ACEPTO LOS TERMINOS DE PROTECCION DE DAÑOS DESCRITOS EN LA PARTE DE ATRAS DE ESTA APLICACION DE CREDITO _____ SI _____ NO

COMO SE ENTERO DE NOSOTROS?

_____ DIRECTORIO
_____ VENDEDOR
_____ EXHIBICION COMERCIAL

CREDITO DESEADO _____

_____ PAGINAS AMARILLAS
_____ PERIODICOS
_____ OTRO

FIRMA

FECHA

Enviar por correo la aplicacion completa a:
RENTALS UNLIMITED, INC.
P.O. BOX 600
CLARKSBURG, MARYLAND 20871

DEPARTAMENTO DE CREDITO
FAX: (301) 972-2557

PROTECCION DE DAÑOS

DEFINICION:

SIEMPRE QUE SE USE EL TERMINO EQUIPO PUEDE SIGNIFICAR CAMIONES, EQUIPO MOBIL, EQUIPO ESTACIONARIO, HERRAMIENTAS DE MANO, ETC. O ALGUN OTRO ARTICULO PARA RENTAR.

PERDIDA O DAÑOS DEL EQUIPO:

EL CLIENTE ES RESPONSABLE POR TODOS LOS DAÑOS, PERDIDA O ROBO DE CAMIONES Y EQUIPO.

PROTECCION DE DAÑOS:

SI EL CLIENTE ACEPTA EL PLAN DE PROTECCION DE DAÑOS, EL CLIENTE NO SERA RESPONSABLE POR NINGUN DAÑO AL EQUIPO PROVEIDO A EXCEPCION DE LOS SIGUIENTES USOS PROHIBIDOS:

- a. USADO PARA ALGUN PROPOSITO ILEGAL O DE MAL MANERA;
- b. USADO CUANDO ESTE EN NECESIDAD DE LUBRICACION, DE REPARACION O CUANDO SEA INSEGURO;
- c. USADO EN CUALQUIER CARRERA, PRUEBA O COMPETENCIA;
- d. USADO MAS ALLA DE LA CAPACIDAD NORMAL;
- e. USADO SIN LAS MEDIDAS DE SEGURIDAD PROVEIDAS;
- f. PRESTADO, ASIGNADO O REALQUILADO;
- g. USADO FUERA DEL ESTADO SIN CONSENTIMIENTO ESCRITO;
- h. OPERADO POR UN MENOR O CONDUCIDO POR UNA PERSONA SIN LICENCIA;
- i. (REMOLQUE): SI ES USADO CON OTRO DIFERENTE AL VEHICULO ESPECIFICADO;
- j. OPERADO MIENTRAS QUE ESTA EMBRIAGADO O DROGADO;
- k. DEJARLO PRENDIDO SIN ATENCION;
- l. USADO EN CUALQUIER LUGAR DIFERENTE AL ESPECIFICADO;
- m. CUALQUIER OTRO USO IRRAZONABLE O MAL INTENCIONADO;
- n. DEJAR LA LLAVE EN EL EQUIPO O VEHICULO.

COSTO:

LA PROTECCION DE DAÑOS ES 12% DEL TOTAL DE LA RENTA.
VEHICULOS, \$14.00 POR DIA, \$98.00 POR SEMANA, \$392.00 POR MES.

We carry a wide selection of Hardware for Delivery or Store Pick-Up !



Gloves



Respirators



Eye and Hearing Protection



Rain Gear



Traffic Safety



Hand Tools



Fuel Cans Ext. Cords



Concrete Forms, Blankets

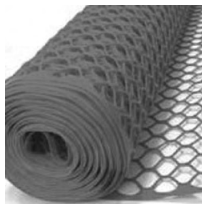
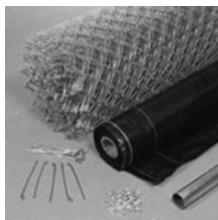

Silt and Safety Fence



Trailer Accessories



Tarps



Diamond Blades



Sand Paper, Screens



Chain, Binding Straps



Job Site Refreshment



WE ARE A FULL SERVICE STIHL DEALER !

